

BC Series Modular Fibre Optic Interface System

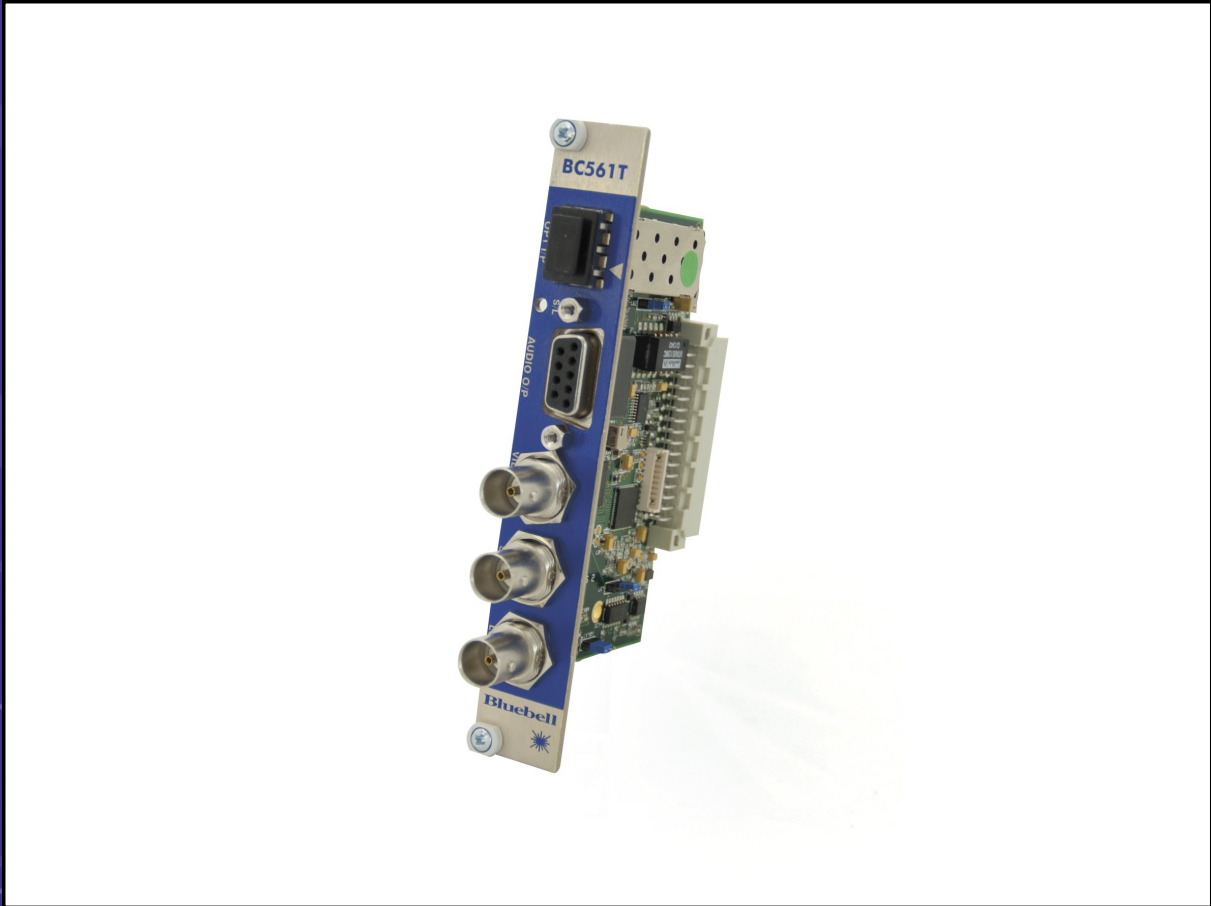

BC561T Electrical to Optical Transceiver

3G-SDI, Composite, Audio

The BC561T is a transmitter card for the transport of a 3G-SDI, HD-SDI, SD-SDI or DVB-ASI signal over fibre optical cable. The incoming signal is auto-sensed and then equalised and reclocked prior to conversion and transmission down a single optical fibre.

A reverse path for 2 x differential analogue audio and a composite/genlock signal is carried on a second fibre making the BC561 perfect for adding cost effective fibre I/O to compact remote camera systems.

The BC561T is available in multimode, singlemode, WDM and CWDM variants to suit any fibre application.

The BC561T occupies a single slot in the BC100-3RU 19" rack-mounting frame which can hold up to 15 single slot cards. Signal and card monitoring is achieved through SNMP monitoring in the BM102 network card.

For stand alone applications the BC561T can be housed in an individual rugged enclosure.

Schematic Diagram BC561T

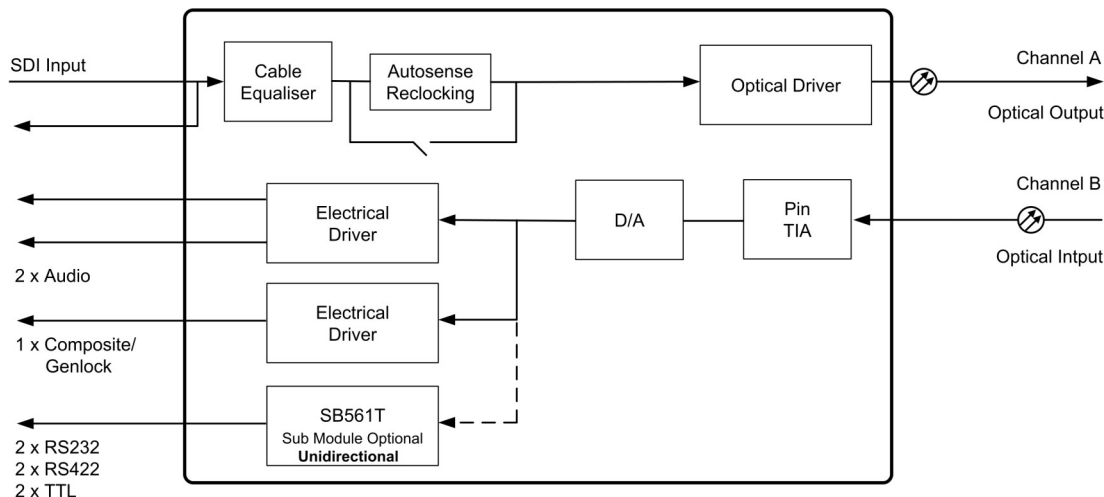

Rear Panel



Specifications for each channel

Electrical Input and Loop Output - SDI

Standards SMPTE 424M, SMPTE 292M, SMPTE 259M, SMPTE 297M, DVB-ASI

Equalisation Automatic to 100 m @ 3 Gb/s
Automatic to 200 m @ 1.485 Gb/s
Automatic to 300 m @ 270 Mb/s
Equaliser and reclocking can be bypassed to support data rates down to 50 Mb/s

Connector 1 x 75 Ohm BNC per IEC 60169-8 Amendment 2
1 x SDI input, 1 x Loop input

Return Loss > 15 dB @ 1.485 Gb/s

Format Reclocked
(with bypass to support data rates down to 50 Mb/s)
Please note that the factory default unless specified is for units to be supplied in reclocking mode.
Non-reclocking settings are accessed via module pcb.

Electrical Output - Video

Connector 1 x 75 Ohm BNC
Format Composite Video/Genlock

Electrical Output

Connector 9 pin D type
Format 2 x differential Analogue Audio

Optical Input/Output

Connector 1 x female LC as standard per channel
Wavelength 1310 nm, 1550 nm,
See Ordering Information
Optical Power -2 dBm @ 1310 nm (typical)
-2 dBm @ 1510 nm (typical)
0 dBm @ CWDM (typical)

Option

By adding the SB561T sub module unidirectional data can also be added to the card functionality. The card is supplied with a different rear panel and becomes a 2 slot device.

SB561T Electrical Output

Connector 9 pin D type
Format 2 x RS323
2 x RS422
2 x TTL

General module specifications

Depth 86 mm¹
Width 20 mm 4HP
Height 129 mm 3RU
Weight 100 g
Operating Temp -30 to +70 °C
Power 2.4 W
No. of slots 1
2 with SB561DT fitted

¹ (Including connectors)

Conformance

EMI/RFI: Complies with 89/336/EEC, EN55022B, EN61000-4-2, EN61000-4-4-(Level 2), EN61000-4-4FTB, EN61000-4-5, EN61000-4-11

Electrical: Complies with EN61000-6-1, EN61000-6-2, EN61000-6-3, EN61000-6-4

Laser Safety: Dependent on SFP fitted.
Complies with Class 1 laser product

RoHS: Complies with Directive 2002/95/EC

Warranty 5 years

Ordering Information

BC561T/S Singlemode 3G/SDI, HD/SDI Fibre Optic Transmitter Module, Auto-Sensing for SDI, ASI, HD/SDI and 3G/SDI (1310nm). With reverse video/genlock and 2 x differential analogue audio on second fibre.

Fitted with LC connectors as standard

SB561 sub module Sub Module adds additional unidirectional data to BC561 board
NB : BC561 becomes a double slot device when the sub board is fitted

SB561DT Sub module for BC561T unit. When fitted it provides outputs for 2 x RS232 + 2 x RS422 + 2 x TTL

For all available enclosures and frames see section "Universal Chassis and Power Supplies".