



OPERATIONS & TECHNICAL MANUAL

For

BC620

8 ch Analogue Audio ↔ Optical

© 2010-2014 Bluebell Opticom Ltd

Unit 2, The Quadrant, Howarth Road, Maidenhead, Berkshire, SL6 1AP United Kingdom

Tel: +44 (0)1628 510055 Fax: +44 (0)1628 510057 Email: sales@bluebell.tv Website: www.bluebell.tv

Please note that all documentation herein is of a confidential nature and may not be reproduced without written confirmation from Bluebell Opticom Ltd. The technical descriptions and schematics are to aid service and repair only. Dissemination to a third party or parties will constitute breach of copyright.

Information in this document is subject to change without notice and does not represent a commitment on the part of Bluebell Opticom Ltd.

© 2010-2015 Bluebell Opticom Ltd
Unit 2, The Quadrant
Howarth Road
Maidenhead
Berkshire
SL6 1AP
United Kingdom

Tel: +44 (0)1628 510055
Fax: +44 (0)1628 510057
Email: support@bluebell.tv
Website: www.bluebell.tv

| | |
|-------------------------------------|----|
| Contents | 3 |
| Description | 4 |
| Specifications | 4 |
| Block diagrams | 5 |
| Panel layouts | 6 |
| Connections | 7 |
| Adjustments / settings / indicators | 8 |
| Circuit descriptions | 9 |
| Component layout BC620 | 10 |
| Component layout BC450T | 12 |
| Component layout BC450R | 14 |
| Schematics BC620 | 16 |
| Schematics BC450T | 19 |
| Schematics BC450R | 22 |
| Parts list BC620 | 25 |
| Parts list BC450T | 27 |
| Parts list BC450R | 29 |

Description

Each Bluebell BC620 module contains two boards; a BC620 baseboard and a conversion board, either a BC450T (optical transmit) or a BC450R (Optical receive).

Data conversion from analogue audio to digital format is provided by the BC450T daughter board (eight channel A to D)

Conversion from digital to analogue format is provided by the BC450R daughter board (eight channel D to A) sub cards.

Conversion of the digital data to and from fibre is performed by the BC620 baseboard. The BC620 module operates from an input voltage of +6V.

Optical input and output are on a SFP module with LC format sockets, multimode and single mode modules can be used.

The optical output power is dependent on the chosen SFP module.

Optical input sensitivity is also dependent on the chosen SFP module.

The audio inputs or outputs are via a 26-way HD D-type connector on the sub board.

Specifications

BC620T

| | |
|---------------------|-----------------------|
| Depth | 74mm incl. connectors |
| Width | 20mm (4HP) |
| Height | 129mm (3RU) |
| Weight | 120g |
| Power Supply | 6V DC |
| Power consumption | 3.5W |
| Current consumption | 570mA |

Audio

| | |
|-----------------------|-------------------------------------|
| Analogue audio output | 4 stereo pairs |
| Audio connector | 26-way female High density "D" type |

BC620R

| | |
|---------------------|-----------------------|
| Depth | 74mm incl. connectors |
| Width | 20mm (4HP) |
| Height | 129mm (3RU) |
| Weight | 120g |
| Power Supply | 6V DC |
| Power consumption | 2.5W |
| Current consumption | 400mA |
| Optical input | |

Audio

| | |
|-----------------------|-------------------------------------|
| Analogue audio output | 4 Stereo pairs |
| Audio connector | 26-way female High density "D" type |

Block diagrams

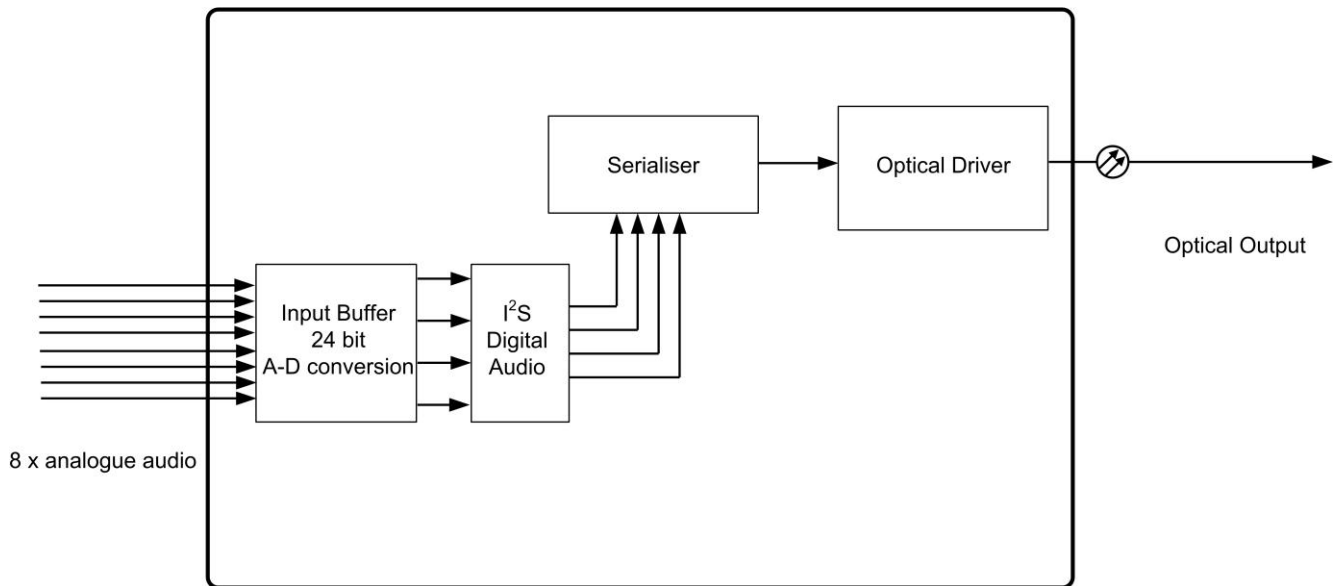

BC620T block diagram

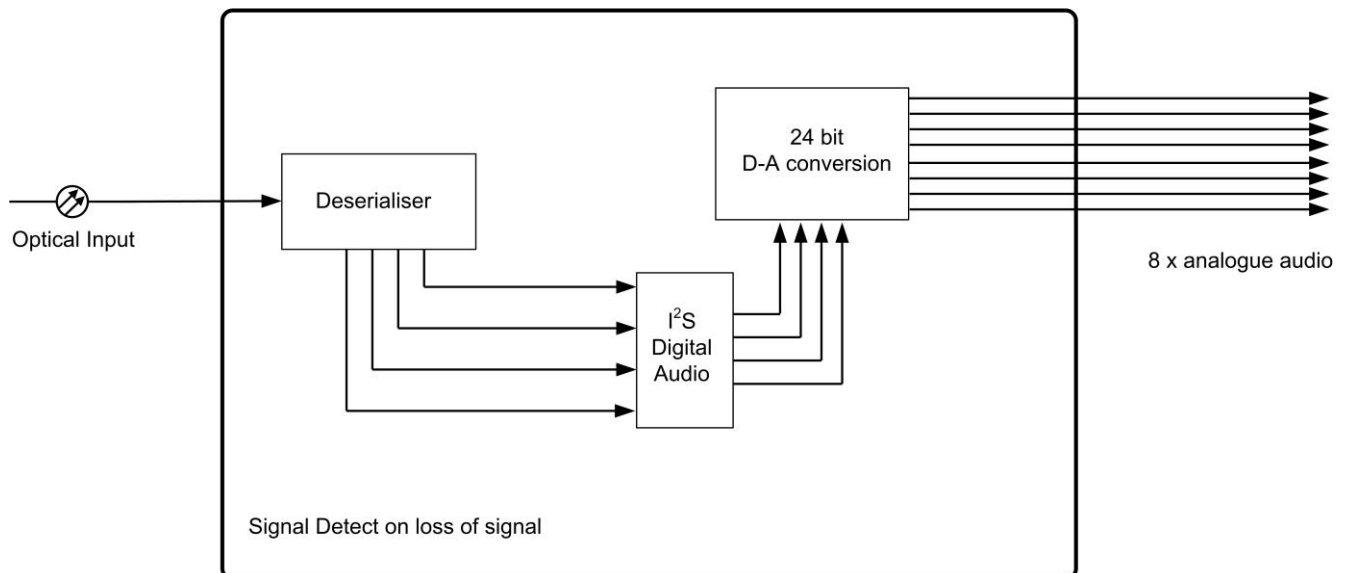

BC620R block diagram

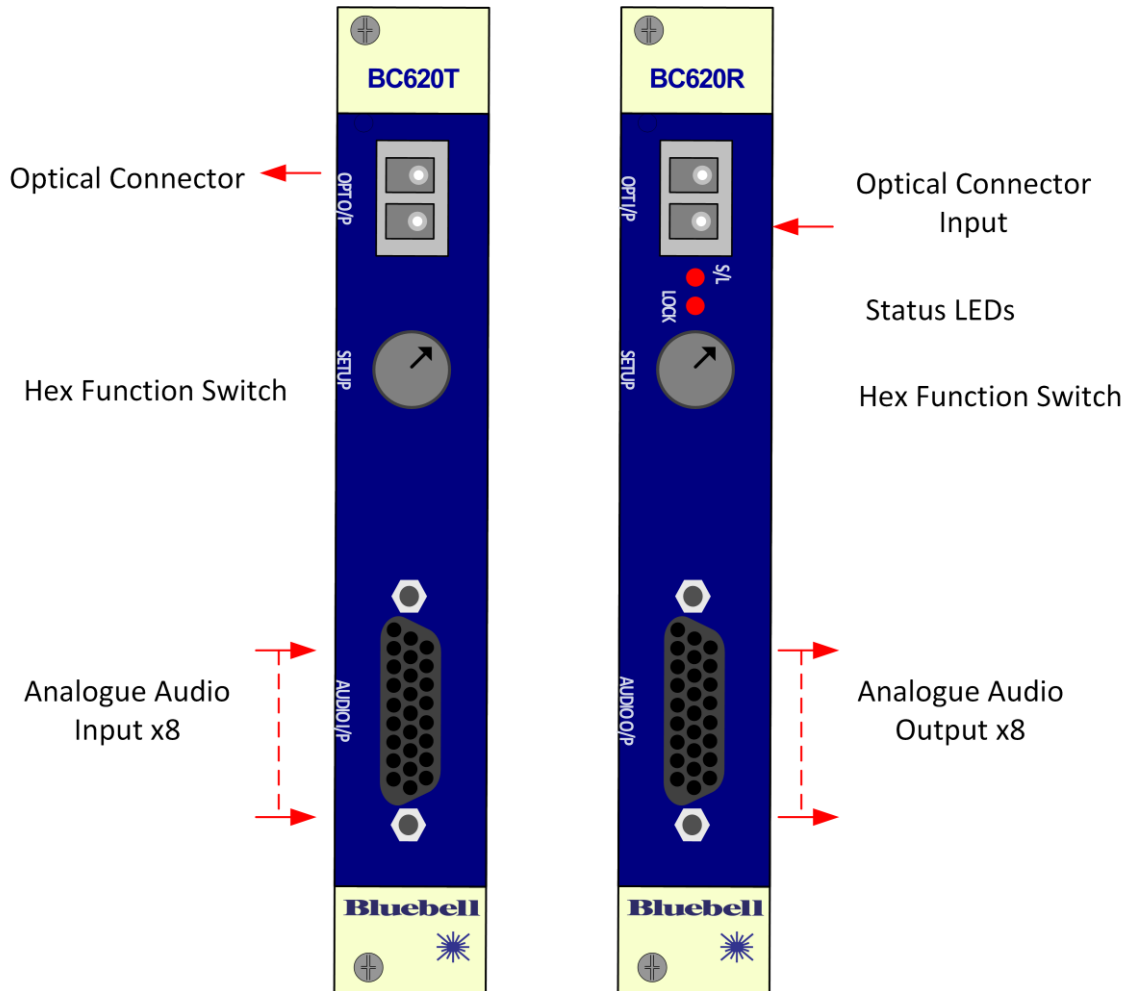

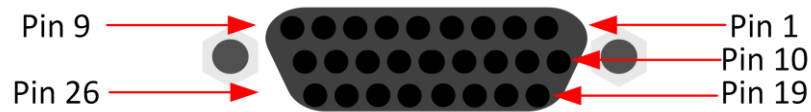

BC620T Analogue Audio input connections:

(* NOTE; Channel B Left & Right are reversed compared to other channels.)

| | | | | | |
|----|----------------|----|---------------------|----|----------------|
| 1 | chan A Left + | 10 | chan A Left screen | 19 | chan A Left - |
| 2 | chan A Right + | 11 | chan A Right screen | 20 | chan A Right - |
| 3* | chan B Right + | 12 | chan B Right screen | 21 | chan B Right - |
| 4* | chan B Left + | 13 | chan B Left screen | 22 | chan B Left - |
| 5 | chan C Left + | 14 | chan C Left screen | 23 | chan C Left - |
| 6 | chan C Right + | 15 | chan C Right screen | 24 | chan C Right - |
| 7 | chan D Left + | 16 | chan D Left screen | 25 | chan D Left - |
| 8 | chan D Right + | 17 | chan D Right screen | 26 | chan D Right - |
| 9 | Ground | 18 | Ground | | |

BC620R - Analogue Audio output connections:

| | | | | | |
|---|----------------|----|---------------------|----|----------------|
| 1 | chan A Left + | 10 | chan A Left screen | 19 | chan A Left - |
| 2 | chan A Right + | 11 | chan A Right screen | 20 | chan A Right - |
| 3 | chan B Left + | 12 | chan B Left screen | 21 | chan B Left - |
| 4 | chan B Right + | 13 | chan B Right screen | 22 | chan B Right - |
| 5 | chan C Left + | 14 | chan C Left screen | 23 | chan C Left - |
| 6 | chan C Right + | 15 | chan C Right screen | 24 | chan C Right - |
| 7 | chan D Left + | 16 | chan D Left screen | 25 | chan D Left - |
| 8 | chan D Right + | 17 | chan D Right screen | 26 | chan D Right - |
| 9 | Ground | 18 | Ground | | |

Adjustments / settings / indicators

| | Link | to Link | |
|--|--|---------|---------------------------|
| On BC450T (Sub board - Analogue audio input settings) | | | |
| LK1 | Pin 1 | Pin 2 | 0dB gain on all channels |
| LK1 | Pin 2 | Pin 3 | +6dB gain on all channels |
| | | | |
| VR1 | Gain adjustment for all channels -1 to +1 dB | | |
| | | | |
| On 620 Baseboard | | | |
| LK4 | | | Not used |
| LK5 | | | Not used |
| HEX switch | No function on 620 | | |
| LED 1 | Not implemented on BC620T | | |
| LED 2 | Not implemented on BC620T | | |

| | Link | to Link | |
|---|--|---------|---------------------------|
| On 450R (Sub board - Analogue audio output settings) | | | |
| LK1 | Pin 1 | Pin 2 | -6dB gain on all channels |
| LK1 | Pin 2 | Pin 3 | 0dB gain on all channels |
| LK1 | Pin 3 | Pin 4 | -4dB gain on all channels |
| | | | |
| VR1 | Gain adjustment for all channels -1 to +1 dB | | |
| | | | |
| On 620 Baseboard | | | |
| LK4 | | | Not used. |
| LK5 | | | Not used |
| HEX switch | No function on 620 | | |
| LED 1 | (Upper LED) Optical strength good | | |
| LED 2 | Signal locked | | |

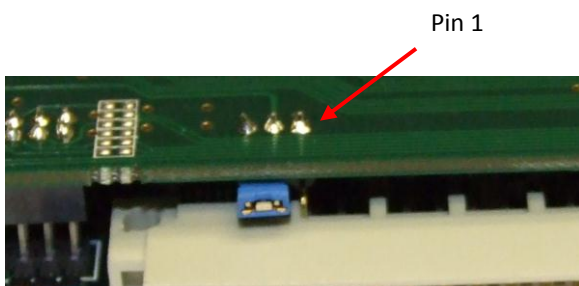

BC620T: 450T sub board Link location

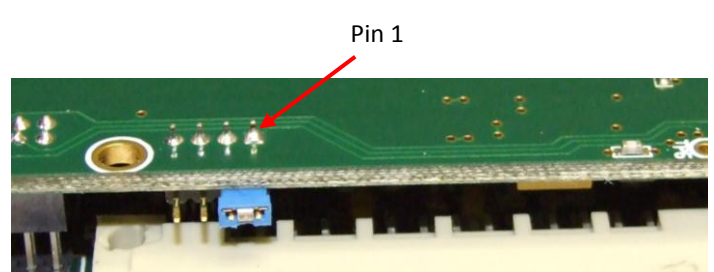

BC620R: 450R sub board Link location