



BN324 Series Fibre Video Interfaces



Thank you for purchasing this Bluebell Opticom professional broadcast video product. The BN324 Series of interfaces are very simple to install and this Quick Start Guide should provide sufficient information to get you up and running in the vast majority of cases.

Quick Start Guide

Safety Warning - Important Precautions

To reduce the risk of fire or electric shock, do not expose this equipment to rain, moisture, or wet conditions.

General Safety Guidelines

- Always **disconnect the entire system from the AC mains** before cleaning or servicing.
- The following product frames - **BC100, BC100i, BC101, BC102, BC120, BC160i** - must be connected using a **three-conductor AC mains power cord with an earth ground**. All three conductors must be used at all times to prevent electric shock.
- Do **not** bypass or disable any fuse.
- Only replace fuses with those of the **specified type and rating**.
- Do **not** use flammable or combustible chemicals for cleaning.
- Do **not** pour or spill liquids directly onto the unit.
- Do **not** allow any liquid to enter the unit or wet the internal components.
- Do **not** operate the unit with any cover or panel removed.
- Do **not** obstruct the ventilation slots—**adequate airflow must be maintained**.
- Do **not** operate the unit in environments with **extreme temperatures**.
- Do **not** use or store the unit in **explosive atmospheres**.
- Do **not** attempt to repair the unit yourself. If servicing is required, please contact your local **Bluebell Opticom distributor**.
-  **Product Warranty**
- **Bluebell Opticom Ltd** provides warranty coverage as detailed in our general terms and conditions.
Please note that warranty support is only valid if **product serial numbers remain intact and legible**. Tampering with or removing serial numbers may void your warranty.

	EN60950	Safety
	EN55103-1: 1996	Emission
	EN55103-2: 1996	Immunity

Bluebell Opticom Ltd



Tested To Comply
With FCC Standards
FOR HOME OR OFFICE USE

This device complies with part 15 of the FCC Rules
Operation is subject to the following two condition:
(1) This device may cause harmful interference, and
(2) This device must accept any interference received,
including
Interference that may cause undesired operation

Power supply:

Overview:

The BN324 Series is a range of compact, stand-alone fibre interfaces, which are primarily intended for video OB applications of up to 4K format. They allow SDI video signals meeting SD, HD, 3G, 6G or 12G standards to be transmitted over fibre-optic cable. Two BNC connectors provide the “copper” connections; the optical port is a dual SFP cage fitted with an appropriate module. The interfaces can alternatively be used for the transmission of MADI data.

This Quick Start Guide covers four variants comprising the range:

- BN324T transmitter - two independent channels, dual SDI inputs to dual fibre outputs
- BN324R receiver - two independent channels, dual fibre inputs to dual SDI outputs
- BN324TR transceiver - two independent channels: channel A is configured as a transmitter, and channel B as a receiver
- BN324A “adaptive” variant - may be supplied with an SFP module of the customer’s choice, or with an empty SFP cage. It allows users to fit SFP modules of their own choice to suit different applications. Depending on the type of SFP module, the BN324A will automatically configure itself as a dual transmitter, a dual receiver, or a transceiver.

The four variants are of identical construction, and in outward appearance differ only in the silk-screened labelling on the interface:

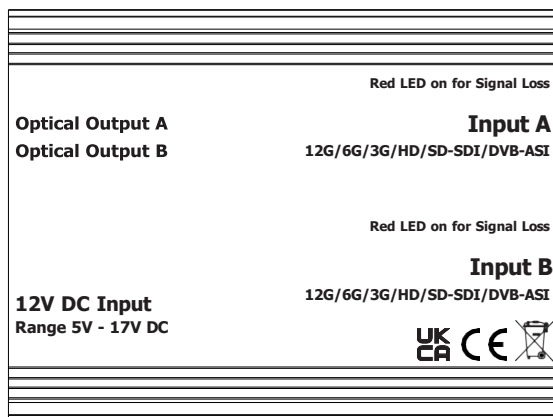

BN324T

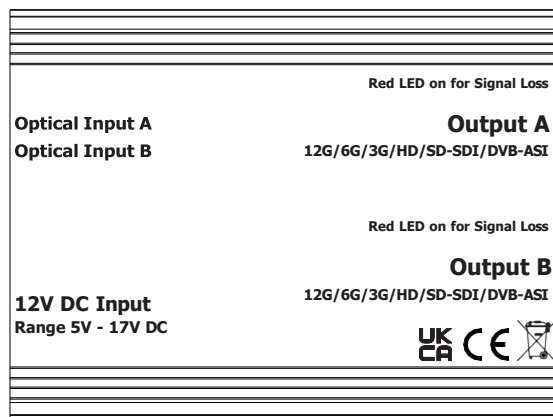

BN324R

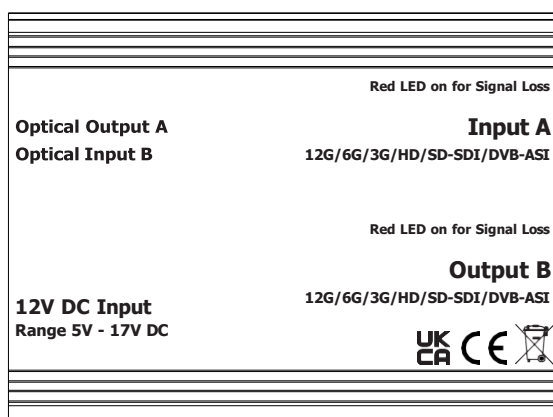

BN324TR

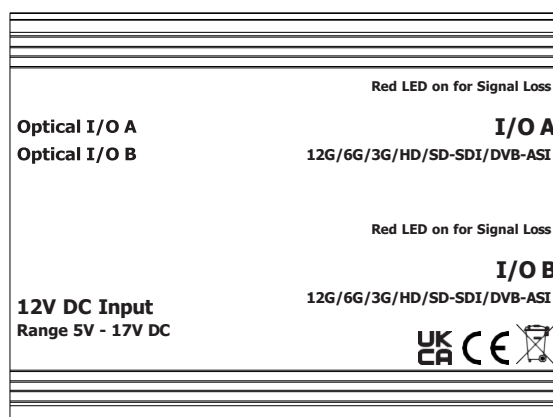

BN324A

Power supply:

All BN324 variants require an external power supply voltage of between 5 and 17 V DC. A Bluebell Model PS12 PSU (12 V) will be packed with the interface if one was ordered. The power supply connector is a Neutrik® XLR4M, and a locking mating connector is pre-fitted to the PS12 DC cable.

Pin	
1	0 V
2	n/c
3	n/c
4	+V DC

If using an alternative PSU, wire the connector as above.

Model	Typical Power Consumption
BN324T	3.0 W (all models)
BN324R	
BN324TR	
BN324A	

The power consumption of the BN324 variants (measured with 2 x 12G SDI signals).

Inputs and outputs:

SDI Video:

BN324 interfaces can be used with serial digital video signals having data rates up to 12 Gb/s. Standards supported are:

SD-SDI: SMPTE ST259M compliant HD-SDI:
SMPTE ST292M compliant 3G-SDI:
SMPTE ST424M compliant 6G-SDI:
SMPTE ST2081 compliant 12G-SDI:
SMPTE ST2082 compliant

ASI baseband streams are also compatible.

Video inputs and outputs are on 75 ohm BNC sockets. All variants have two connectors: inputs on the BN324T and outputs on the BN324R; the BN324TR has one input and one output. The signal direction at the BNCs on the BN324A will depend on the SFP module fitted.

MADI:

BN324 interfaces can also be used to transmit and/or receive MADI data streams via the BNC connectors. The interfaces are agnostic to MADI format - 56/64 channels, 48/96 kHz frame rate, and all standard sample rates from 44.1 kHz to 192 kHz. The optical data rate is fixed at 125 Mb/s.

Power supply:

Optical (BN324T, BN324R, BN324TR):

An SFP cage fitted with a dual LC optical module is standard on the BN324T, BN324R and BN324TR; the module type will depend on the variant. Each SDI channel uses one of the two optical fibre ports.

Optical operation is single-mode. The standard transmission wavelength is 1310 nm; a dual-wavelength version (1310 and 1510 nm) is also available. Transmitters fitted with lasers tuned to specific CWDM wavelengths are also available. Any of the alternative options will have been specified at the time of order.

Note that the optical receivers in the BN324R and BN324TR are wideband, and can be used with all wavelengths in the range 1270 – 1610 nm.

Optical (BN324A);

The BN324A may be supplied with an empty SFP cage for users to fit their own SFP modules, and change them as operational needs require. The type of module fitted - dual transmitter, dual receiver or single channel transceiver - is automatically detected and the interface configured to suit.

IMPORTANT: BN324 interfaces will only operate correctly when fitted with **non-MSA** SFP modules: note that this restriction applies to **all** variants.

Apart from Bluebell Opticom's own SFP modules, modules from the following manufacturers were tested and approved for use with the BN324A in April 2022:

- Embrionix
- Eoptolink
- Optoway

Please contact Bluebell Opticom if you wish to use SFPs from other manufacturers.

Using the BN324:

Normally, BN324 units will be used in pairs, either with a BN324T/BN324R pair at the two ends of the fibre run, or by using a pair of BN324TR interfaces for bi-directional operation. A BN324A may be substituted for any of the other three variants, depending on the SFP module fitted.

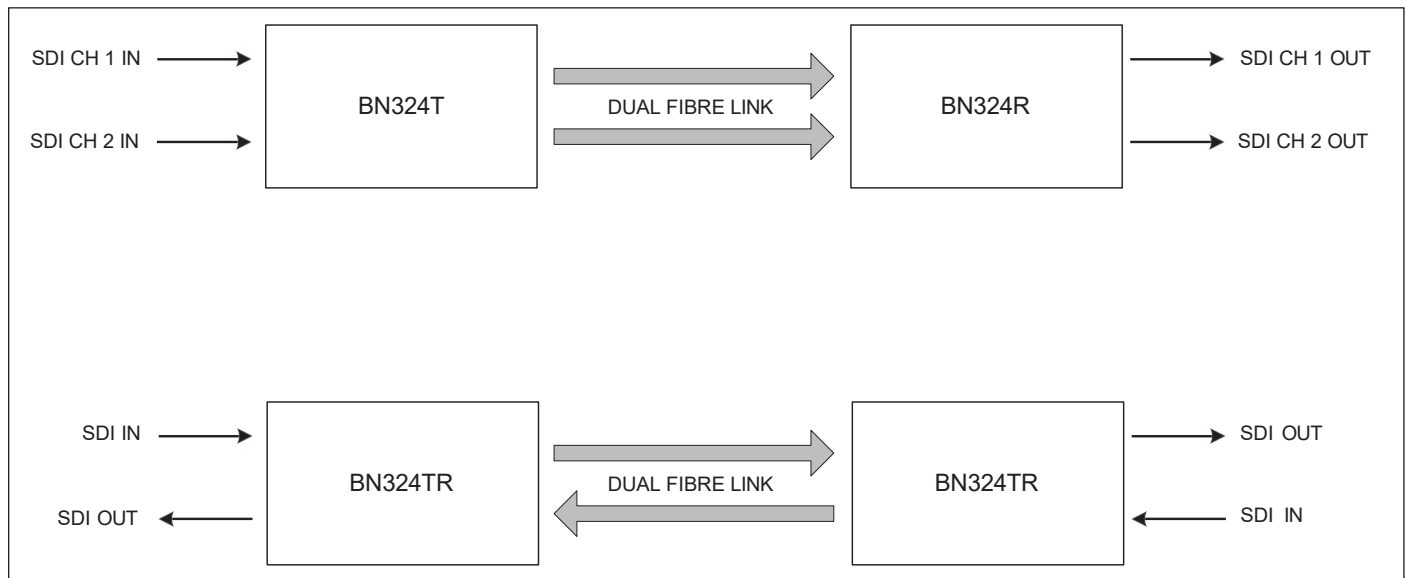

LEDs:

On all models, bi-colour LEDs are fitted adjacent to each of the BNC connectors. These illuminate **green** to confirm a valid input signal (SD/HD/3G/6G/12G SDI or MADI), or **red** to indicate either no signal or a signal which is in some way invalid. On a BN324T, the LEDs monitor the incoming SDI video (or MADI) signal, on a BN324R, they confirm the receipt of a valid optical signal. The LEDs on a BN324TR monitor the video input on the transmit channel and the optical input on the receive channel.

The LEDs on a BN324A will mimic those on a BN324T, BN324R or BN324TR as described above, depending on the SFP module fitted.

NOTE: For any technical issues not covered in this Quick Start Guide, please contact Bluebell Opticom.

Contact details:

Bluebell Opticom Ltd.
Unit 2, The Quadrant
Howarth Road
Maidenhead
Berkshire
SL6 1AP
United Kingdom

Tel: +44 (0) 1628 510055
Email: support@bluebell.tv
Web: www.bluebell.tv