

Bluebell Opticom Ltd.
Unit 2, The Quadrant
Howarth Road
Maidenhead
Berkshire
SL6 1AP
United Kingdom

Tel: +44 (0) 1628 510055
Fax: +44 (0) 1628 510057
Email: support@bluebell.tv
Web: www.bluebell.tv

Please note that all documentation herein is of a confidential nature and may not be reproduced without written confirmation from Bluebell Opticom Ltd. The technical descriptions and schematics are to aid service and repair only. Dissemination to a third party or parties will constitute breach of copyright.

Information in this document is subject to change without notice and does not represent a commitment on the part of Bluebell Opticom Ltd.

Bluebell Opticom Limited has taken all possible steps to ensure that the information given here is both correct and complete. In no event can Bluebell Opticom Limited accept any liability or responsibility for any loss or damage to the owner of the equipment, any third party, or any equipment which may result from use of this manual or the equipment which it describes.

Declaration of Conformities

Bluebell Opticom Limited hereby declares that the BM102i Network Monitoring Card with Ethernet Connection is in compliance with the essential requirements and other relevant provisions of the following EU directives: 89/336/ EEC and has been assessed to EN55023B (European limits and methods of measurement of radio disturbance characteristics); EN61000-4-2, EN61000-4-4 (Level 2), EN61000-4-4FTB, EN61000-4-5 and EN61000-4-11 (EMC); EN61000-6-1, EN61000-6-2, EC61000-6-3 and EC61000-6-4 (Immunity to electrical emissions).

RoSH and WEEE declaration

Bluebell Opticom Limited manages its business and collaborates with its suppliers to comply with the European Union restriction of the use of certain hazardous substances in electrical and electronic equipment, RoHS Directive (2002/95/EC), that came into force on 1st July 2006, and similar restrictions in other jurisdictions.

Customer participation is important to minimize the potential effects on the environment and human health that can result from hazardous substances that may be contained in this product. Please dispose of this product and its packaging in accordance with local and national disposal regulations, including those governing the recovery and recycling of waste electrical and electronic equipment. Contact your local waste administration, waste collection company or dealer.

Safety Warning – Important Precautions

To reduce the risk of fire or electric shock, do not expose this equipment to rain, moisture, or wet conditions.

General Safety Guidelines

- Always **disconnect the entire system from the AC mains** before cleaning or servicing.
- The following product frames – **BC100, BC100i, BC101, BC102, BC120, BC160i** – must be connected using a **three-conductor AC mains power cord with an earth ground**. All three conductors must be used at all times to prevent electric shock.
- Do **not** bypass or disable any fuse.
- Only replace fuses with those of the **specified type and rating**.
- Do **not** use flammable or combustible chemicals for cleaning.
- Do **not** pour or spill liquids directly onto the unit.
- Do **not** allow any liquid to enter the unit or wet the internal components.
- Do **not** operate the unit with any cover or panel removed.
- Do **not** obstruct the ventilation slots—**adequate airflow must be maintained**.
- Do **not** operate the unit in environments with **extreme temperatures**.
- Do **not** use or store the unit in **explosive atmospheres**.
- Do **not** attempt to repair the unit yourself. If servicing is required, please contact your local **Bluebell Opticom** distributor.



Product Warranty

- **Bluebell Opticom Ltd** provides warranty coverage as detailed in our general terms and conditions.
Please note that warranty support is only valid **if product serial numbers remain intact and legible**. Tampering with or removing serial numbers may void your warranty.

Table of Contents

Content	4
Overview	5
Introduction	5
Product pictures	7
BM102i card slot	7
Quick Start Guide	8
Panel Connections	9
Panel Settings	9
OPTIONS Hex Switch	9
RESET Push button	10
LED indicators	10
Switches Settings (internal to card – SW1)	10
Network Monitoring Webpage	11
Overview Page	11
Frame Information Page	13
Network Configuration Page	15
SNMP Configuration Page	15
Updating web GUI/Uploading an Image File	16
Specifications	16
Main parts and related products	17
IN-DEPTH USER GUIDE	18
Block Diagram	18
Configuration via Ethernet	19
Ethernet	19
Network Configuration page	20
SNMP Configuration page	22
Uploading 'Image' files	23
Configuration via USB port	24
Serial Configuration Menu	25
Operations	30
Network Port	30
'Pinging' the Card	30
Internal Web Pages	30
SNMP	32
Group 1 - 'Basic' parameters	32
Group 2 - 'CardTable' parameters	34
SNMP Traps	38
Configuring Traps	38
Generating Traps	38

Overview

Introduction

The BM102i monitoring card reports various status parameters of all 15 cards in a BC100i-3RU frame or of the 6 cards in a BC160i-1RU frame, plus the diagnostic parameters such as supply voltage of the dual power supplies, frame temperature and the cooling fans status. The BM102i card makes these parameters and statuses available via its RJ45 Ethernet 10BASE-T port to an SNMP environment. The card also has a built-in web pages that can be used to monitor the frames.

The statuses reported by the BM102i comprise the following:

- Frame status
 - Frame Temperature
 - Power Supply 1, Power Supply 2 internal supply voltage and status
 - Power Supply 1, Power Supply 2 temperature and status (BC100i only)
 - Fan failure
 - Last frame reset
- For each BC-series card (see Note below):
 - Signal present or absent for channels A and B
 - Card present or absent
 - Card type, serial number and functional description
 - Card hardware and firmware revision levels
 - Card specific parameter (some advanced cards report additional monitoring)
- For cards with a SFP optical modules:
 - SFP Manufacturer and Model number
 - SFP temperature and supply voltage and out-of-range statuses
 - SFP transmitter wavelength and bias current
 - SFP transmitter or receiver optical power

NOTE: The range of BC-series cards have been updated over the years to provide the additional status information listed above. Some 'old' cards only report signal status for channels A and B. Cards with a memory (eeprom) gives further information stated above.

Card configuration can be achieved via the built-in web pages.

Ethernet signal status indication is provided on the RJ45 connector by LED indicators. The green left LED indicates a valid connection and the amber right LED shows data flow.

The green LED marked "STATUS" on the front panel flashes when the main program is running, collecting status information, and providing Ethernet access.

A 'MIB' file is available to allow integration into third party SNMP Management Software such as HP OpenView connector.

Parameters reported by BM102i	
From the BM102i	Card type, serial number, hardware rev., firmware rev.
	Last reset
	Supply voltage + status
From the Frame	PSU1, PSU2 faults
	Frame temperature + status
	Frame internal voltage from both power supplies + status
	Fan status
From cards in the frame (if detected)	Card type (part number)
	Card present
	Card function summary (brief summary)
	Card serial number
	Card hardware revision
	Card firmware revision
	Signal loss channel A, B
Card Specific Parameters	CSPs are extra parameters reported by certain cards with intelligence. These parameters may include input/output signal data rates or card's current function modes and more.
From SFPs (if detected)	SFP manufacturer
	SFP Type (part number)
	SFP temperature
	SFP temperature status
	SFP supply voltage
	SFP supply voltage status
	SFP signal direction (Tx/Rx) ch1, ch2
	SFP bias current ch1, ch2
	SFP bias current status ch1, ch2
	SFP optic power ch1, ch2
	SFP optic power status ch1, ch2

NOTE:

- The parameters reported by the SFPs are reported by the SFP itself. Users should be aware that not all SFPs are fully compliant with SFP reporting standards, and that this may be particularly so with older or time-expired SFPs.
- Some previous versions of cards only report signal loss of channel A, B. Therefore, the card will be reported as not present but signal loss would be detected.
- In some cases, the electrical channels A and B will correspond to the SFP optical channels 1 and 2. However, this is not always the case, which is why the optical channels are not labelled as A and B.

Product Pictures



BM102i card slot

BC100i:

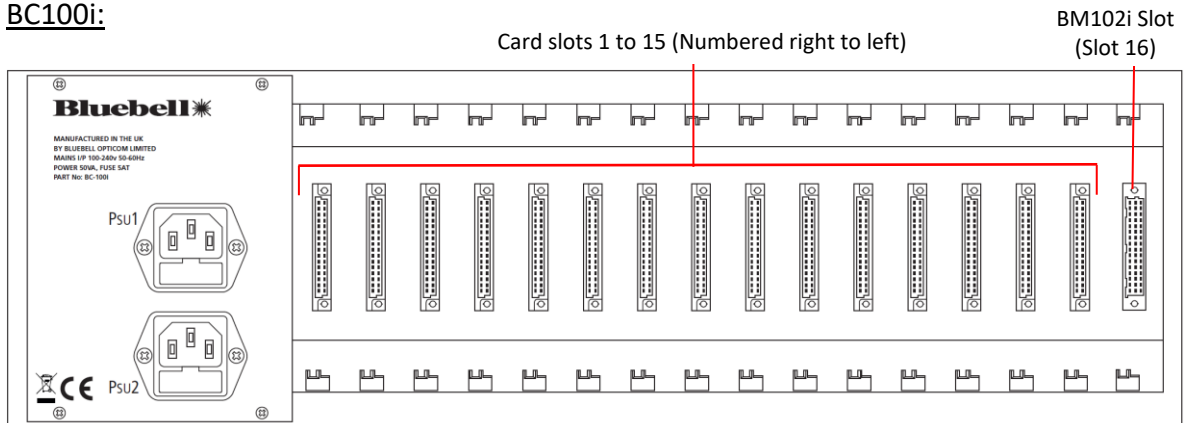

In a BC100i-3RU frame, the BM102i goes into Slot 16 at the rear side of the frame.

BC160i:

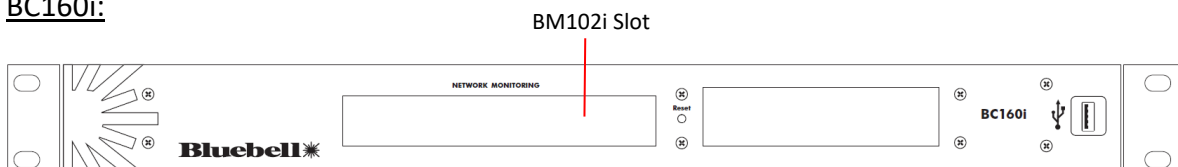

In a BC160i-1RU frame, the BM102i goes into its dedicated slot in the front of the frame.

NOTE: See frame manual for more information

Quick Start Guide

Before its first use, a BM102i card should normally be configured, which can be done via an ethernet network and a web browser.

From the factory, the card's default settings are as follows:

```
Host name:                BM102i
Static IP address:        192.168.16.200
Static gateway address:   192.168.16.2
Static subnet mask:       255.255.255.0
Static primary DNS server: 192.168.16.2
Static secondary DNS server: 0.0.0.0
DHCP is enabled
```

The BM102i can be connected to a network either by a straight ethernet cable connected to a router or switcher, or a crossover cable connected directly to a PC.

By default, DHCP is enabled on the card, and so if the network supports this, a different IP address will be assigned to the card when it is first connected to the network. Your network administrator should be able to determine the new IP address.

The BM102i's internal web page should be accessible via a standard web browser on the network. If the IP address is not known, the card should still be accessible by its default name:

<http://bm102i/>

Or by its re-assigned IP address or its default IP address (if not changed by DHCP):

<http://192.168.16.200/>

If these methods fail, it may be necessary to configure the card using a serial configuration cable (see **Configuration via USB port**). The serial port will also display any new IP address assigned by DHCP.

From the home page you should then be able to select the "Network Configuration" tab which is password protected. When the prompt comes up, enter the username and password provided by bluebell:

```
User name:  admin
Password:   settings
```

The Network Configuration page will allow you to change the IP addresses, the DHCP status, and the card's Host name to suit your network. If you access this page, please make a note of the MAC address in case it gets reset to default, and needs to be re-instated later.

SNMP

The SNMP Configuration page (which uses the same User name and password as the Network Configuration page) allows setting of the SNMP Community names.

The card has a corresponding 'mib' file which would normally need to be loaded into your Network Management System (NMS) or mib browser.

If not supplied with the card, a mib file for SNMP use can be obtained by emailing support@bluebell.tv.

Please note that BM102i mib files are incompatible with early versions of the BM102 mib file.

Configuring the SNMP traps is done using SET operations on the appropriate SNMP parameters.

Panel Connections

USB

This USB-B connector is for optional, engineering use (see "Configuration via USB port" section above).

NETWORK PORT

This is an RJ45 connector for a standard ethernet network cable. It provides access to the card's internal web pages, and monitoring information via SNMP.

Panel Settings

OPTIONS Hex Switch

Pos	Function
0	Normal operation
1	Normal operation
2	Normal operation
3	Normal operation
4	Normal operation
5	Normal operation
6	simulate slots 1-6 (Ch 6A fails - Trap on sig 6A)
7	simulate slots 1-7 (Ch 6B fails - Trap on sig 6B)
8	simulate even slots (Channels B fail)
9	simulate odd slots (Channels B fail)
A	simulate all slots (Channels A fail)
B	simulate all slots (Channels B fail)
C	simulate all slots
D	simulate all slots (All sigs fail)
E	normal operation
F	Serial configuration menu on screen on next reset when configuring via USB

Positions 6 through D provide a "demo" mode, giving simulated responses for some card slots (overriding any real cards that are present). This may be helpful in analysing monitoring systems, particularly when no cards are available (or even no frame, with a loose BM102i powered by USB cable).

RESET Push button

This button will perform a reset to the on-card micro-processor, similar to the powering-up of the card. This may be required during some configuration operations (see elsewhere in manual) but may also help in a fault lock-up situation (e.g. if the "STATUS" LED is not flashing, with the "OPTIONS" switch at 0). Normal operation of the "RESET" button (i.e. with SW1-2 in its normal position and "OPTIONS" switch at 0) may abort any monitoring operations in progress, but is otherwise safe, as all the non-volatile settings of the card (e.g. MAC address, IP address, SNMP 'sys' parameters etc.) will be preserved.

LED indicators

Indicator	Function
Network Port	Green – Lit to show a valid ethernet connection is detected Amber – Flickers on data flow
Status LED (D2)	Toggles on-off every 500ms when running normally. (does not flash when in serial configuration mode)
Debugging LED (D1)	On when accessing SRAM, off when not accessing SRAM

Switches Settings (internal to card – SW1)

Switch	Position	Operation
SW1 - 1	Off	Normal operation (default)
"	On	No function assigned as yet
SW1 - 2	Off	Normal operation (default)
"	On	Set configuration to default values on next reset

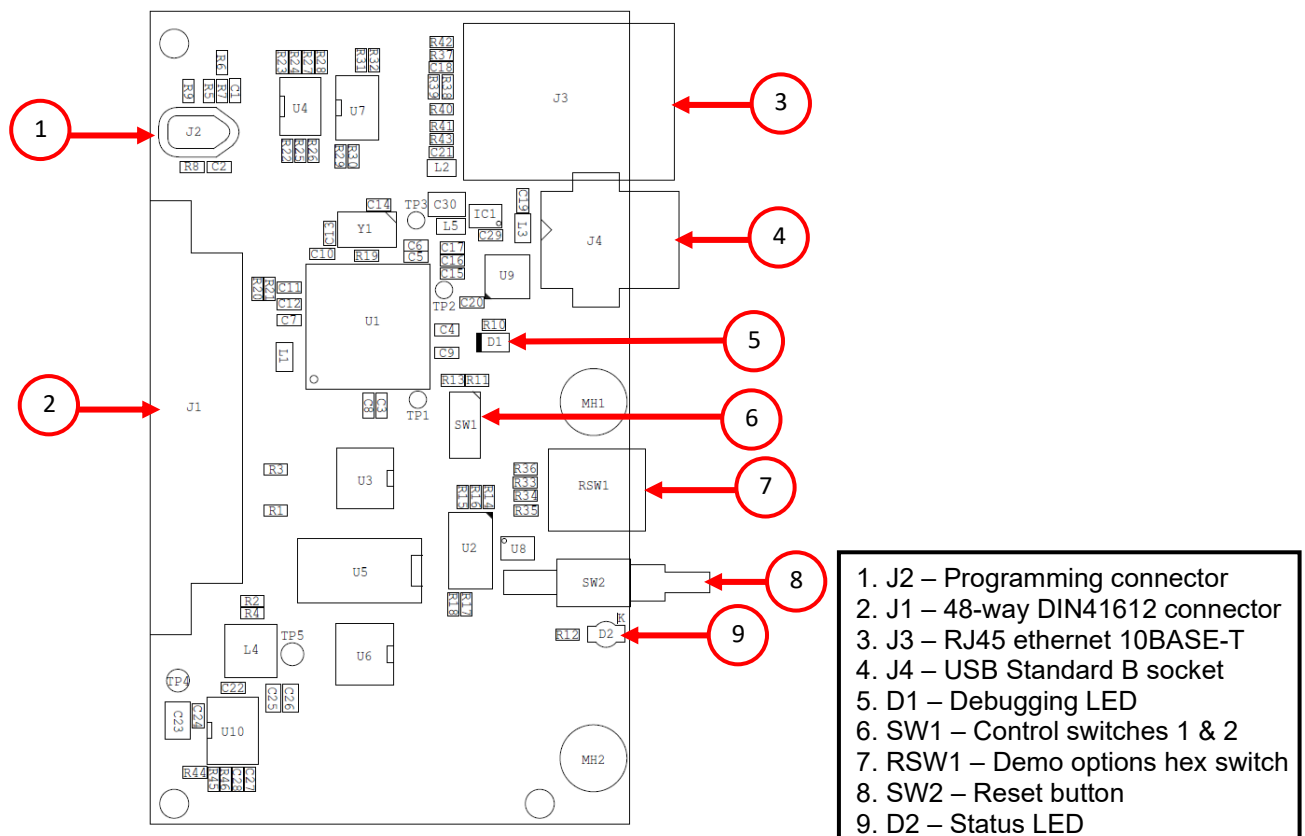

Network Monitoring Webpage

The BM102i has the ability to distinguish whether the frame is a BC160i and BC100i. The firmware and image file are compatible with both types of frames and will update the webpage accordingly, showing the slots in the layout of the frames.

Overview Page

Bluebell Frame: PUBLIC FRAME 1

Overview | Frame Information | Network Configuration | SNMP Configuration

This page shows the main signal status for all the cards in a BC series Frame.

Slot	1	2	3	4	5	6	7	8	9	10	11	12	13	14	15
Card Type	BC370R	BC501R		BC623	BC369	BC369		BC365R	BC365T	BC365T	BC501T	BC362R			BC370T
A LED	Red	Green	Off	Red	Red	Red	Off	Red	Red	Red	Green	Red	Off	Off	Red
B LED	Red	Red	Off	Red	Red	Red	Off	Red	Red	Red	Green	Red	Off	Off	Red

BC100i: PSU 1 PSU 2 Temperature Fans
 Network status

The LEDs indicate the following:

- Red LED:** Signal faulty or missing
- Green LED:** Signal present
- Off LED:** No card in that slot, OR v1 card without status monitoring but with signal present

Local Time: 20/12 - 10:51:08

For help, email: support@bluebell.tv

Firmware Date: Oct 11 2019 15:36:56 Image Date: Jun 19 2019 16:50:00

Copyright © 2012 Microchip Technology, Inc. © 2013-2019 Bluebell Opticom Ltd.

The Overview Page is the first page which comes when the BM102i's IP-address is entered. The main purpose of this page is to give a summary the primary status of each card installed in the frame.

- Each card installed reports its identity to the frame monitoring system: the type is displayed below the slot number. Clicking on the slot number or card name will take the user to card information page where more specific data to the card itself is displayed.

NOTE: a few older types of BC Series cards do not report their identities.

- This area has been designed to mimic the LED status array fitted to the front panel of the Bluebell BC100i frame. Each of the 15 card slots is represented by a coloured rectangle containing two bicolour "virtual LEDs".

In each slot:

- Blue rectangle – card present
- Black rectangle – no card detected

- Green LED – valid signal detected, or no channel present on card (applicable only to certain single-channel cards)
 - Red LED – no valid signal detected
3. Basic information about the BC100i frame’s operation and status: the two power supply unit status, temperature of the frame itself and fan status. As the fan is optional on the BC100i, if no fan is fitted then there will be no fan status displayed.
 4. Tabs to direct the user to a different page, current page is dark blue – All pages are discussed in this document.
 5. Basic information about the BM102i card: Network status, green = good ethernet connection, red = ethernet connection lost.
 6. BM102i firmware date and image file date. This information must be included when contacting support regarding the BM102i.

Further example of the Overview page is shown below:

This page shows the main signal status for all the cards in a BC series Frame.

Slot	Label	LED Status
B	5	Off
A	3 BC368	Green
B	1 BC364	Green
A	6 BC370R	Red
B	4 BC365T	Green
A	2	Off

BC160i: PSU 1 (Green), PSU 2 (Red), Temperature: 27 degC, Fans (Green)

BM102i: Network status (Green)

The LEDs indicate the following:

- Red LED:** Signal faulty or missing
- Green LED:** Signal present
- Off LED:** No card in that slot, OR v1 card without status monitoring but with signal present

Local Time: 20/12 - 10:57:24

For help, email: support@bluebell.tv Firmware Date: Oct 11 2019 15:36:56 Image Date: Jun 19 2019 16:50:00
 Copyright © 2012 Microchip Technology, Inc. © 2013-2019 Bluebell Opticom Ltd.

Overview page is show for the BC160i, where the slots and LEDs mimic the layout of the frame. All other features are explained on the BC100i Overview page above.

Frame Information Page

Bluebell Frame: PUBLIC FRAME 1

Overview **Frame Information** Network Configuration SNMP Configuration

This page shows the extra information provided by the cards and their SFP modules where fitted. Select: Select unit

1 BC370R	2 BC501R	3	4 BC623	5 BC369	6 BC369	7	8 BC365R	9 BC365T	10 BC365T	11 BC501T	12 BC362R	13	14	15 BC370T
0 BC100i														
16 BM102i														

CARD in Slot 0

Card type	BC100i	S/N eeprom detected	yes
Card Function summary	Frame 3U, 15slot	Card Serial number	11495-417
Card Hardware Revision	4.00	Card Firmware Revision	18Oct19
PSU 1 status	good	PSU 2 status	fail

BC100i specific parameters

Last reset	00001d 01h 23m 39s	Fan status	good
Frame temperature	24 degC	Frame temp. status	Ok
PSU1 supply voltage	6702 mV	PSU1 voltage status	Ok
PSU1 temperature	46 degC	PSU1 temp. status	Ok
PSU2 supply voltage	0 mV	PSU2 voltage status	Too low
PSU2 temperature	26 degC	PSU2 temp. status	Ok

For help, email: support@bluebell.tv Firmware Date: Oct 11 2019 15:36:56 Image Date: Jun 19 2019 16:50:00

Copyright © 2012 Microchip Technology, Inc. © 2013-2019 Bluebell Opticom Ltd.

The Frame page displays more detailed information about the BC100i frame itself, and about all the cards inserted in the frame. The tabular page layout is consistent for all card types, though some fields will be empty depending on what data the cards can provide.

- Each card installed reports its identity to the frame monitoring system: the card type is displayed below the slot number. Clicking on the slot number or card name will take the user to card information page where more specific data to the card itself is displayed. The user can also use the drop down menu to select a slot.
NOTE: a few older types of BC Series cards do not report their identities.
- Confirms the card type in this slot, serial number, PCB issue and firmware version – this information may be needed when contacting Bluebell with any technical issues that arise with the card.
- Tabs to direct the user to a different page, current page is dark blue – All pages are discussed in this document.
- Card Specific Parameters are extra information provided by the cards. Some (basic) cards do not report these extra parameters. Please see the frame/card manual for more information regarding these parameters.
- BM102i firmware date and image file date. This information must be included when contacting support regarding the BM102i.

Further examples of frame information page are shown below:

1	2	3	4	5	6	7	8	9	10	11	12	13	14	15
BC370R	BC501R		BC623	BC369	BC369		BC365R	BC365T	BC365T	BC501T	BC362R		BC390T	BC370T

0	16
BC100i	BM102i

CARD in Slot 14

Card type	BC390T	S/N eeprom detected	yes
Card Function summary	4x HD-12G SDI -> 2	Card Serial number	CT002
Card Hardware Revision	1	Card Firmware Revision	2.01
Card ch A signal status	fail	Card ch B signal status	fail

BC390T specific parameters

I/P 1	No Lock	O/P 1	No Lock
I/P 2	No Lock	O/P 2	No Lock
I/P 3	No Lock		
I/P 4	No Lock		
		Mode	7
O/P 2 copies 1	Enabled (1)	Mode Seln	Manual (1)

SFP 1

Temperature	18 deg C	Supply voltage	3363 mV	
Temperature status	ok	Supply voltage status	ok	
SFP Manufacturer	ViITA	SFP Manufacturer's type	VPC-S1-4103K-F	
SFP signal direction ch 1	transmit	SFP signal direction ch 2	transmit	
SFP Wavelength ch 1	1310 nm	SFP Wavelength ch 2	1310 nm	
SFP Bias current ch 1	20 mA	SFP Bias current ch 2	20 mA	
SFP Bias current ch 1 status	ok	SFP Bias current ch 2 status	ok	
SFP optic power ch 1	-2.6 dBm (553 uW)	SFP optic power ch 2	-1.8 dBm (667 uW)	
SFP optic power ch 1 status	ok	SFP optic power ch 2 status	ok	

Example 1: Card type BC390T (4k SDI multiplexer with four SDI inputs and single SFP transmitter carrier, designed to perform a variety of format conversions. The BC390T Card Specific Parameters are updated regularly to view any changes in signal speed or mode changes. SFP table displays a more detailed information about each SFP. Note that SFP data will only be shown when an SFP is detected in the slot. Cards with multiple SFP carriers will show multiple SFP tables when detected.

NOTE: SFP data displayed on this page is that reported by the SFP itself. Users should be aware that not all SFPs are fully compliant with SFP reporting standards, and that this may be particularly so with older or time-expired SFPs. Apparently incorrect data may therefore originate with the SFP's reporting mechanism itself, and may not necessarily indicate a dysfunctional SFP.

1	2	3	4	5	6	7	8	9	10	11	12	13	14	15
BC370R	BC501R		BC623	BC369	BC369		BC365R	BC365T	BC365T	BC501T	BC362R		BC390T	BC370T

0	16
BC100i	BM102i

CARD in Slot 16

Card type	BM102i	S/N eeprom detected	yes
Card Function summary	Frame Monitor	Card Serial number	114360-28
Card Hardware Revision	1	Card Firmware Revision	Oct 11 2019 15:36:56
Fans status (if fitted)	good		

BM102i specific parameters

Last reset	00049d 03h 51m 02s		
Supply voltage	5990 mV	Supply voltage status	ok

Example 2: Confirms the network card's data in slot 16. Serial number, PCB issue and firmware version - This information may be needed when contacting Bluebell with any technical issues that arising with the card. Last reset displayed on the network card is independent to that show on the frame page (slot 0).

Network Configuration Page

The Network Configuration Page will allow the user to change the IP addresses, the DHCP status, and the card's Host name to suit your network. Please make a note of the MAC address when accessing this page in case it gets reset to default, and needs to be re-instated later.

Overview	Frame Information	Network Configuration	SNMP Configuration																		
<p>This page allows the board's network settings to be configured by entering new values in the form below, then clicking the Save Config button.</p> <p>CAUTION: Incorrect settings may cause the board to lose network connectivity. Recovery options will be provided on the next page.</p>																					
<table> <tr> <td>MAC Address:</td> <td>00:50:C2:7C:94:0C</td> </tr> <tr> <td>Host Name:</td> <td>BM102I</td> </tr> <tr> <td><input checked="" type="checkbox"/> Enable DHCP</td> <td></td> </tr> <tr> <td>IP Address:</td> <td>192.168.16.200</td> </tr> <tr> <td>Gateway:</td> <td>192.168.16.2</td> </tr> <tr> <td>Subnet Mask:</td> <td>255.255.255.0</td> </tr> <tr> <td>Primary DNS:</td> <td>192.168.16.2</td> </tr> <tr> <td>Secondary DNS:</td> <td>0.0.0.0</td> </tr> <tr> <td colspan="2" style="text-align: right;"><input type="button" value="Save Config"/></td> </tr> </table>				MAC Address:	00:50:C2:7C:94:0C	Host Name:	BM102I	<input checked="" type="checkbox"/> Enable DHCP		IP Address:	192.168.16.200	Gateway:	192.168.16.2	Subnet Mask:	255.255.255.0	Primary DNS:	192.168.16.2	Secondary DNS:	0.0.0.0	<input type="button" value="Save Config"/>	
MAC Address:	00:50:C2:7C:94:0C																				
Host Name:	BM102I																				
<input checked="" type="checkbox"/> Enable DHCP																					
IP Address:	192.168.16.200																				
Gateway:	192.168.16.2																				
Subnet Mask:	255.255.255.0																				
Primary DNS:	192.168.16.2																				
Secondary DNS:	0.0.0.0																				
<input type="button" value="Save Config"/>																					

The Network Configuration page is password protected. When the prompt comes up, enter the username and password provided by bluebell:

User name: admin
Password: settings

If any parameters have been changed, press "Save Config". The BM102i will do a soft reset and start up with the new parameters (this will not affect the functionality of all the other cards in the frame). These data will be stored in the network card's memory and will be used after every reset.

SNMP Configuration Page

Overview	Frame Information	Network Configuration	SNMP Configuration																										
<p>Read/Write Community String configuration for SNMPv2c Agent.</p> <p>Configure multiple community names if you want the SNMP agent to respond to the NMS/SNMP manager with different read and write community names. If less than three communities are needed, leave extra fields blank to disable them.</p>																													
<table> <tr> <td colspan="2">SNMP TRAPS:</td> </tr> <tr> <td>Trap Status:</td> <td><input checked="" type="radio"/> Enable <input type="radio"/> Disable</td> </tr> <tr> <td>Trap Version:</td> <td><input type="radio"/> SNMP v1 <input checked="" type="radio"/> SNMP v2c</td> </tr> <tr> <td>Trap Receiver IP:</td> <td>192.168.16.34</td> </tr> <tr> <td>Trap Community:</td> <td></td> </tr> <tr> <td colspan="2">SNMP READ/WRITE COMMUNITY NAMES:</td> </tr> <tr> <td>Read Comm1 :</td> <td>public</td> </tr> <tr> <td>Read Comm2 :</td> <td>read</td> </tr> <tr> <td>Read Comm3 :</td> <td></td> </tr> <tr> <td>Write Comm1:</td> <td>private</td> </tr> <tr> <td>Write Comm2:</td> <td>write</td> </tr> <tr> <td>Write Comm3:</td> <td>public</td> </tr> <tr> <td colspan="2" style="text-align: right;"><input type="button" value="Save Config"/></td> </tr> </table>				SNMP TRAPS:		Trap Status:	<input checked="" type="radio"/> Enable <input type="radio"/> Disable	Trap Version:	<input type="radio"/> SNMP v1 <input checked="" type="radio"/> SNMP v2c	Trap Receiver IP:	192.168.16.34	Trap Community:		SNMP READ/WRITE COMMUNITY NAMES:		Read Comm1 :	public	Read Comm2 :	read	Read Comm3 :		Write Comm1:	private	Write Comm2:	write	Write Comm3:	public	<input type="button" value="Save Config"/>	
SNMP TRAPS:																													
Trap Status:	<input checked="" type="radio"/> Enable <input type="radio"/> Disable																												
Trap Version:	<input type="radio"/> SNMP v1 <input checked="" type="radio"/> SNMP v2c																												
Trap Receiver IP:	192.168.16.34																												
Trap Community:																													
SNMP READ/WRITE COMMUNITY NAMES:																													
Read Comm1 :	public																												
Read Comm2 :	read																												
Read Comm3 :																													
Write Comm1:	private																												
Write Comm2:	write																												
Write Comm3:	public																												
<input type="button" value="Save Config"/>																													

The card uses SNMP v2c polling and v1/v2 traps. The SNMP Configuration page allows the user to set the community names to be used for SNMP. This page is also password protected (same as Network Configuration Page).

The page allows up to 3 community names each for Read and Write accesses. Each name can be up to 31 characters long. Other SNMP parameters are configured using the SNMP 'Set' command. These include the 'System' values (Contact, Name, and Location) and the Trap parameters (Enabled/Disabled, Receiver IP address, and Trap Community name) for each of two trap generators. See the SNMP entry in the 'Operations' section below for more information.

Updating web GUI/Uploading an Image File

Image files can be updated using the monitoring webpages. Before an image file is uploaded, please ensure the file is compatible with the BM102i firmware on the network card. For guidance, email support at Bluebell with the BM102i's firmware date.

To upload an image file, enter the network card's IP-address with "/imageupload". For example:

<http://192.168.16.200/imageupload>

The MPFS Image Upload page will be displayed once the above address is entered.

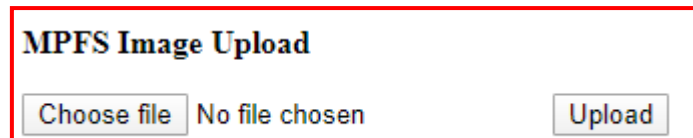

Click on "Choose file" and upload the image file (.bl2 file). Press "Upload" to update the image file on the BM102i card. If no file or wrong file is chosen, the user will get an error message of "MPFS Image Corrupt or Wrong Version" and will be prompted to try again.

The IP-address and host name of the network card remains the same when a new image file is uploaded. The **Overview page** can be accessed the same way as before, using the same IP-address or host name.

Please ensure the image date shown on the bottom of the webpage is the one that is required. Contact Bluebell Support if unsure or if any issues arise.

Specification

BM102i General Specifications	
Width	20mm (4HP)
Height	129mm (3RU)
Depth	75mm
Weight	170g
Power supply	4.5 - 6V DC
Power consumption	1.0W (160mA at +6V DC)
Operating temperature range	-30°C to +70°C
Electrical connections	48-way DIN41612 connector USB Standard B socket Ethernet 10BASE-T
Warranty	5 years

Conformities	
EMI/RFI	89/336/EEC, EN55022B, EN61000-4-2, EN61000-4-4 (Level 2), EN61000-4-4FTB, EN61000-4-5, EN61000-4-11
Electrical	EN61000-6-1, EN61000-6-2, EN61000-6-3, EN61000-6-4

Main Parts and Related Products

Part No.	Description
BM102i	Network Monitoring Card with Ethernet connection.
BC160i	19" 1RU frame for up to 6 BCxxx Cards, with Dual Redundant Power Supplies, integrated microprocessor-based card/frame monitoring and 3.8" touchscreen. Monitoring card is optional and accessible via dedicated slot in the front of the frame.
BC100i	19" 3RU frame for up to 15 BCxxx Cards, with Dual Redundant Power Supplies, integrated microprocessor-based card/frame monitoring and 7" touchscreen. Monitoring card is optional and accessible via dedicated rear slot.
PS100i	90-250VAC 100-Watt Power Supply for BC100i frame. Two required per frame for redundancy.
Optical Flight Case	Ruggedised aluminium flight case housing a BC100i 3RU frame. Any combination of cards, including WDM & CWDM, can be fitted for complete flexibility. Dual mains inputs with forced air cooling and a rugged rear panel is fitted with BNC, XLR and optical connectors as necessary. Contact the UK Sales Office for a written quotation.

IN-DEPTH USER GUIDE

The Quick Start Guide, above, should give enough information to get the card operational. This section gives a more detailed information on the various configuration facilities to allow customers to fully grasp the capability of the BM102i Network Monitoring Card.

Block Diagram

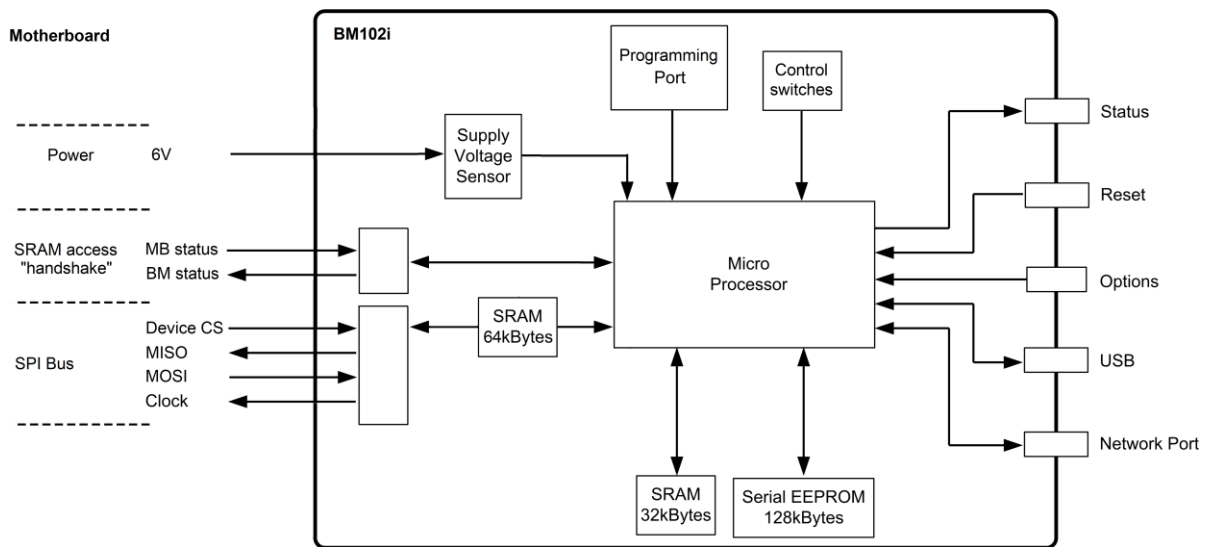

The frame's motherboard (BC100i or BC160i) has a microprocessor which gathers all data from all the cards and SFPs inserted in the frame. All of this data is passed down to a 64KB SRAM on the BM102i via SPI protocol. The BM102i's microprocessor then reads the data from the SRAM and transmits it for network monitoring over the network port.

The status LED on the BM102i must toggle consistently on-off every 500ms. If this LED is stuck on/off, or has inconsistent toggling, then a card reset may resolve the issue. A press of the reset button will not affect the cards in the frame, but will only reset the microprocessor chip in the BM102i.

USB port is mainly used for programming the card's serial number and MAC address. It can also be used for debugging or fault finding. Various commands are explained in the **Configuration via USB** section below.

Network port on the BM102i is a RJ45 Ethernet 10BASE-T port, giving access to an **SNMP environment** and the **internal web pages**. These internal web pages mimic the LCD display on the 1RU/3RU frames, allowing users to monitor the status of the frame and of all the cards inserted.

"Options" settings are explained in the quick start guide under **OPTIONS Hex Switch**. There are two control switches on the card, identified as SW1, shown in the **Switches Settings** section and their function is summarised here:

- SW1-1: Set to off by default, but this switch has no function as yet. It may be assigned a function in the future.
- SW1-2: Set to off by default, but switching this on will return the configuration settings to their default values the next time the card is reset or powered up. If the USB serial cable is in place and a terminal emulator running, then the following messages will be displayed:

```
Default settings restored.  
PLEASE de-select before next reset.
```

Once invoked, SW1-2 should be returned to the off position.

The 3 SNMP sys parameters: sysContact, sysName, sysLocation, are cleared to default bluebell parameters.

It may also clear the card's memory of its own serial number (readable over SNMP) and so this should be restored using the **Serial Configuration Menu**.

Configuration via Ethernet

Ethernet

From the factory, the card's default network settings are as follows:

```
Host name:           BM102i  
IP address:         192.168.16.200  
Gateway address:   192.168.16.254  
Subnet mask:       255.255.255.0  
Primary DNS server: 192.168.16.1  
Secondary DNS server: 0.0.0.0  
DHCP:              Enabled
```

The BM102i can be connected to a network either by a straight ethernet cable connected to a router or switcher, or a crossover cable connected directly to a PC.

By default, DHCP is enabled on the card, and so if the network supports this, it will assign a different IP address to the card. If a serial configuration cable is connected (see **Configuration via USB port**) the new IP address will be reported on the terminal. Otherwise, your network administrator may be able to determine the new IP address.

The card's internal web page can be accessed from its IP address, if known, by running a web browser and entering the address (for example, default shown):

<http://192.168.16.200/>

If the IP address is not known, the network card should still be accessible by its default host name:

<http://bm102i/>

Either of these methods should display the card's home page which shows the basic status of the other cards in the frame. From here you can navigate to other web pages in the card.

Network Configuration page

Overview

Frame Information

Network Configuration

SNMP Configuration

This page allows the board's network settings to be configured by entering new values in the form below, then clicking the **Save Config** button.

CAUTION: Incorrect settings may cause the board to lose network connectivity. Recovery options will be provided on the next page.

MAC Address:	00:50:C2:7C:94:0C
Host Name:	BM102I
	<input checked="" type="checkbox"/> Enable DHCP
IP Address:	192.168.16.200
Gateway:	192.168.16.2
Subnet Mask:	255.255.255.0
Primary DNS:	192.168.16.2
Secondary DNS:	0.0.0.0
	<input type="button" value="Save Config"/>

From the home page you should then be able to select the "Network Configuration" tab which is password protected.

When the prompt comes up, enter

User name: admin

Password: settings

There is no facility for a user to change this password. Once the password is entered it remains valid for the rest of the browsing session, and you can navigate all the card's webpages without having to re-enter the password. Once you have configured the card, it is advisable to close the browser to cancel the access to the configuration pages, and then re-start it, if required, for monitoring with restored password protection to the configuration pages.

The Network Configuration page will allow users to change the card's MAC address, Host Name, and IP addresses to suit your network. If there are any difficulties accessing this page, these parameters can be changed using a USB serial cable (see **Configuration via USB** section below). More information on the settings is given below.

MAC Address

This value is set at the factory and should not be changed. It is worth making a note of this value so that it can be restored if it does get corrupted. After a "Reset to Default" operation using SW1-2 (see **Card Settings** above) the MAC address may be reset to its default value of 00:50:C2:7C:90:00. If you see this value, you should re-instate the correct value (which will always be higher than the default value) as soon as possible.

If it gets corrupted and you don't know its correct value, please email support@bluebell.tv with the card's serial number (printed label on the card) and they should be able to tell you the correct MAC serial number to be entered.

If the value is changed, it will only be effective after the "Save Config" button is clicked (see below).

Host Name

This name is a maximum 15 characters and is included to be used by the NetBIOS Naming Service (NBNS). This allows the card to be accessed in a web browser with its host name (case insensitive). For example, with the default name, the card can be accessed by:

<http://bm102i/>

You should consult your network administrator to supply different names for multiple cards on a network. The name will be converted to all upper case and should not include 'space' characters if it is to be used in web browsers.

Please note that this name will only be available on your local subnet, and will not be accessible from the Internet. Also, this service is not supported by all operating systems. If you have difficulty accessing your board by this means you will have to use the IP address instead.

If this host name is changed from the default "BM102i", the new name will be displayed on the display screen of the BC100i. This will help identify the frames if multiple frames are in one rack.

If the value is changed, it will only be effective after the "Save Config" button is clicked (see below).

Enable DHCP

Click on the box to toggle the state of this option. The Dynamic Host Configuration Protocol (DHCP) is a method of assigning IP and gateway addresses and subnet masks automatically from a DHCP server on a network. If enabled, and there is such a server on your network, then it will provide values that will override the values for IP Address, Gateway, Subnet Mask, Primary DNS, and Secondary DNS. These options will thus be greyed out if DHCP is enabled (ticked).

If the value is changed, it will only be effective after the "Save Config" button is clicked (see below).

IP Address

This can only be changed when the "Enable DHCP" option is disabled (unticked).

This is the IP address to access this card, for example by typing this address into a web browser on your network. It will be overridden if DHCP is being used. To get the correct value for this, ask the Network administrator or IT specialist where the card is to be installed.

If the value is changed, it will only be effective after the "Save Config" button is clicked (see below).

Gateway

This can only be changed when the "Enable DHCP" option is disabled (unticked).

The correct value for the gateway should be provided by your Network administrator or IT specialist.

If the value is changed, it will only be effective after the “Save Config” button is clicked (see below).

Subnet Mask

This can only be changed when the “Enable DHCP” option is disabled (unticked).

The value for the subnet mask should be provided by your Network administrator or IT specialist.

If the value is changed, it will only be effective after the “Save Config” button is clicked (see below).

Primary & Secondary DNS

The Domain Name System (DNS) is not used on this card and so changing these addresses will not have any effect.

Save Config

If you make changes to any of the values on this page, but then change your mind and wish to abandon the changes, simply click on the “Network Configuration” tab again, and the screen will be refreshed with the original values.

When all the required changes have been made to the values on this page, click on the “Save Config” button. This action will save the new values, re-boot the BM102i, and show a “Reboot In Progress...” page on the web browser, which gives some advice on recovery in case there are any problems with the new settings.

SNMP Configuration page

Read/Write Community String configuration for SNMPv2c Agent.

Configure multiple community names if you want the SNMP agent to respond to the NMS/SNMP manager with different read and write community names. If less than three communities are needed, leave extra fields blank to disable them.

SNMP TRAPS:

Trap Status: Enable Disable

Trap Version: SNMP v1 SNMP v2c

Trap Receiver IP:

Trap Community:

SNMP READ/WRITE COMMUNITY NAMES:

Read Comm1 :

Read Comm2 :

Read Comm3 :

Write Comm1:

Write Comm2:

Write Comm3:

BM102i uses SNMP v1 or v2 traps and v2c polling. The SNMP Configuration page allows the user to set the traps parameters and community names to be used for SNMP.

From the card’s home page (or any page) the SNMP Configuration page can be accessed by clicking on the SNMP Configuration tab, but it requires a password on its first access in

any browsing session. The password access is the same as for the Network Configuration page (see above).

The page allows up to 3 community names each for Read and Write accesses. Each name can be up to 31 characters long.

Save Config

If you make changes to any of the values on this page, but then change your mind and wish to abandon the changes, simply click on the "SNMP Configuration" menu option again, and the screen will be refreshed with the original values.

When all the required changes have been made to the values on this page, click on the "Save Config" button. This action will save the new values, and re-display the page. If any name is longer than 31 characters, it will be rejected, and the old name will be shown. When saved, the names are non-volatile and will survive any power-downs of the card.

Other SNMP parameters are configured using the SNMP 'Set' command. These include the 'System' values (Contact, Name, and Location) and the Trap parameters (Enabled/Disabled, Receiver IP address, and Trap Community name) for each of two trap generators. See the SNMP entry in the 'Operations' section below for more information.

Uploading 'Image' files

Apart from the main software on the card, which cannot normally be changed by a customer, there is also an 'image' file which can be uploaded by a customer to a re-writable memory chip on the card.

An 'image' file incorporates the following components:

- 1 – A file defining the SNMP information, corresponding to the 'mib' file.
- 2 – One or more web pages (.htm and other support files) that the card will then provide to an internet browser.

Cards are supplied from the factory with the latest release 'image' file pre-loaded and so this option is not normally needed. However, updates to the image file (with a filename of the form *Img*.bin) may be provided by Bluebell for uploading to the card by the customer.

For this procedure, the BM102i should be in its normal operating mode, with its STATUS LED flashing once per second, and an ethernet cable connected to a computer running a web browser. The Image file should be loaded onto that computer.

The card will normally be accessed from the web browser using its Host Name (see above). If the Host Name has been changed from its default of "BM102i" then you'll need to replace "bm102i" in the address below with the new host name.

Open a web browser and access the board at

<http://bm102i/imageupload>

or by its IP address, e.g.:

<http://192.168.16.200/imageupload>

This should produce a page headed "MPFS Image Upload" (MPFS is the File System used by the card).

If you mistype this URL, the board will provide a default HTTP 404 error page with a link to the "MPFS Upload" page. This default 404 page will not appear if you've configured your browser to override custom error pages (e.g. if the "Show friendly HTTP error messages" is ticked in Internet Explorer 7's internet options menu).

On the "MPFS Image Upload" page, click on the "Browse..." button to navigate to the required Image file. Then click on the "Upload" button. The image file is sent to the board and programmed into the EEPROM. As this happens, the activity LED on the Ethernet jack will blink. Once the browser reports that the upload has completed, click the link provided within the status message to access the board's web pages.

Configuration via USB port

The USB serial port should not normally be needed either to set up or to operate the card, but it may be needed if there is any difficulty in accessing the card via ethernet, or for more fundamental configuration such as setting the card's serial number if it becomes corrupted.

Serial Cable

The "USB" connector on the front panel is a standard USB-B socket and can be connected to a PC via a standard USB A-B cable. When first plugged in, a PC connected to the Internet will probably download and install a driver automatically. If not, it may be necessary to download a driver manually. The chip used on the BM102i is an FT232RQ made by FTDI (Future Technology Devices International Ltd) and drivers are available from their website:

<http://www.ftdichip.com/>

The driver creates a virtual com port for the BM102i connection and assigns it to the next available COM port number, which can then be set in your preferred terminal emulation program. The COM port number can also be found under device manager in the PC's settings.

Stand-alone Operation

A BM102i card that is outside of a BC-series frame can be powered by the USB cable alone, which may be useful for diagnostic purposes. In this case you can still connect an ethernet cable and access the card's internal webpages and SNMP features. A card can be configured in this way before being plugged into a frame.

Positions 6 through D provide a "demo" mode, giving simulated responses for some card slots (overriding any real cards that are present). This may be helpful in analysing monitoring systems, particularly when no cards are available (or even no frame, with a loose BM102i powered by USB cable). All option settings are listed in the table in the **Panel Settings** section above. These features were added for initial testing and may be removed/changed in later versions of the software.

Running a Terminal Emulator on the PC

On the PC you need to run a simple terminal emulation program such as HyperTerminal. There are a number of public domain terminal programs available, such as Tera Term, PuTTY, Terminal, FoxTerm. These programs can be used for accessing most functions of the BM102i configuration menu, but one function (uploading 'image' file updates to the webpage) requires XMODEM file transfers. Many public domain terminal emulators either do not support XMODEM, or work unreliably with the BM102i (perhaps because the BM102i has to write each block to eeprom memory before receiving the next one and some terminal emulators can't cope with this reduced speed). The only programs we have found (so far) to upload these files reliably are HyperTerminal (bundled with older Microsoft operating systems) and ExtraPuTTY: a freeware available from:

<http://www.extraputty.com/>

The appropriate COM port should be set to:-

- 19200 bps,
- 8 data bits, 1 STOP bit, and no parity
- No flow control
- XMODEM file transfer (to upload 'image' files)

Serial Configuration Menu

With a serial cable connected and the PC running a terminal program, the configuration menu can be accessed with either one of two ways:

- Type "98x" to display the config menu. The OPTIONS switch can be on any mode and there is no need for a card reset for the config menu to show.
- Or, set the OPTIONS switch on the front panel to "F" and press the RESET button. On coming out of reset the terminal program should display the Serial Configuration menu screen (see below).

When using this 'configuration' mode, the following points should be noted:

1. While the configuration menu is active, the card is not servicing the ethernet port and the STATUS LED will not be flashing, to indicate that the card is not in normal operation. Exiting the menu with options 'S', 'Q', or 'Esc' will resume normal operation.
2. Menu options can be entered in either upper or lower case.
3. When all required changes have been made, they will only be saved to non-volatile memory if the menu is exited using option 'S'. There is the option to exit the menu with 'Q' or 'Esc' which means the changes will persist as long as the card is powered, but if the card is reset or powered down then the old values will be restored. (The one exception to this is the option: I: Upload Image File... which writes directly to non-volatile memory while staying in the Configuration menu and so cannot be undone).

Here is the default configuration menu:

```

1 → >98x
    Card Monitor Configuration Screen
2 → Firmware Version: Oct 15 2019 15:36:56
    Image file Version: Jun 19 2019 16:50:00

3 → 2: Change host name: BM102I
    3: Change static IP address: 192.168.16.200
    4: Change static gateway address: 192.168.16.2
    5: Change static subnet mask: 255.255.255.0
    6: Change static primary DNS server: 192.168.16.2
    7: Change static secondary DNS server: 0.0.0.0
    8: Disable DHCP: DHCP is enabled

    I: Upload Image File...
    C: Change Card serial number: 95373.00-001
    M: Change MAC number: 37133

    S: Save & Quit.
    Q: Quit without saving.
Enter a menu choice:

```

1. Command to invoke config menu
2. Firmware and Image file version
3. Enter number/letter to change parameter (see details below)

The menu choices are described further here:

2: Change host name:

This name (maximum 15 characters) is included to be used by the NetBIOS Naming Service (NBNS) and so allows the card to be accessed in a web browser on your local network using this name (case insensitive). For example, with the default name, bm102i, the card can be accessed by:

<http://bm102i/>

Network administrator should be consulted to supply different names for multiple cards on a network. The name will be converted to all upper case and it is advisable not to use 'space' characters in the name as this prevents using the name to access the card in a web browser. Note that any new value will only be saved to non-volatile memory if the menu is later exited by option **S**.

3: Change static IP address:

This is the IP address to access this card. It will be overridden if DHCP is being used. To get the correct value for this, ask the Network administrator or IT specialist where the card is to be installed.

To change the value, type **3** which will give the response:

New Setting:

Enter the four decimal numbers, separated by full stops (e.g. 192.168.39.123) then press **Return**. The card will refresh the menu showing the new value. Note that any new value will only be saved to non-volatile memory if the menu is later exited by option **S**.

4: Change static gateway address:

The correct value for the gateway should be provided by your Network administrator or IT specialist.

To change the value, type **4** which will give the response:

New setting:

Enter the four decimal numbers, separated by full stops (period) then press **Return**. The card will refresh the menu showing the new value. Note that any new value will only be saved to non-volatile memory if the menu is later exited by option **S**.

5: Change static subnet mask:

The value for the subnet mask should also be provided by your network administrator or IT specialist.

To change the value, type **5** which will give the response:

New setting:

Enter the four decimal numbers, separated by full stops (period) then press **Return**. The card will refresh the menu showing the new value. Note that any new value will only be saved to non-volatile memory if the menu is later exited by option **S**.

6: Change static primary DNS server:

7: Change static secondary DNS server:

The Domain Name System (DNS) is not used on this card and so changing these addresses will not have any effect.

8: Disable DHCP:

The Dynamic Host Configuration Protocol (DHCP) is a method of assigning IP and gateway addresses and subnet masks automatically from a DHCP server on a network. If enabled, and there is such a server on your network, then it will provide values that will override the values shown against menu options 3, 4, and 5 above. If DHCP is disabled then the static values in menu options 3, 4, and 5 are the ones that will be used.

Typing **8** will toggle the state of DHCP with the new state being shown on the right side of the 8: option in the re-drawn menu. Note that the new state will only be saved to non-volatile memory if the menu is later exited by option **S**.

I: Upload Image File...

An 'image' file can be uploaded to the card which incorporates the following components:

- 1 – A file defining the SNMP information, corresponding to the 'mib' file.
- 2 – One or more web pages (.htm files and assorted support files) that the card will then provide to an internet browser.

Cards are supplied from the factory with a standard 'image' file pre-loaded and so this option is not normally needed. However, updates to the image file (with a filename of the form *Img*.bin) may be provided by Bluebell for uploading to the card by the customer.

The easiest way to upload such a file is via the network cable from a web browser (see method in the **Uploading 'Image' files** section above). Uploading via the serial cable with this menu option is an alternative in case the first method provides any difficulty.

If a new image file is to be uploaded, it should first be copied to the computer which has the serial connection to the BM102i card. Then, at the "Enter a menu choice:" prompt on the serial configuration menu, type the letter: **I**. The card will respond by outputting the ascii NAK character (shows as **§** on HyperTerminal) every half-second.

If using HyperTerminal, select **Transfer -> Send File...** In the [Send File] window, click **Browse...** to select the correct image file from the computer's disk, then select **Xmodem** as the protocol, then click [**Send**]. A window should then show the progress of the file being uploaded, after which the card will refresh the menu to show the uploading was successful.

If using ExtraPuTTY, select **Files Transfer -> Xmodem -> Send**. In the [Select files to upload...] window, navigate to the appropriate folder, select the correct image file from the computer's disk, then click on the [**Open**] button. A [Transferring File] window should then show the progress of the file being uploaded, after which the card will refresh the menu to show the uploading was successful.

If using a different terminal program, there should be equivalent means of sending a file using the Xmodem protocol.

If no other menu items are required, the '**Esc**' key can be pressed to exit the menu and resume normal card operation. Note that this image file is written directly to non-volatile memory and so will persist after later power-downs, irrespective of whether the menu is exited by option **S**, **Q** or **Esc**.

C: Change Card serial number:

The card's serial number is set in the factory and should not normally be changed. This option is included in case the original value gets corrupted. The card's serial number should be printed on a white label stuck on the back of the card. If any issues arise with the BM102i, the serial number must be given to help identify the card.

The serial number shown in the menu is the value that will be reported back using SNMP. If the value looks corrupted, or disagrees with the value on the label, then this menu item can be used to correct it.

To change the value, type **C** which will give the response:

New Setting:

Enter the required value followed by **Return**. The card will refresh the menu showing the new value. Note that any new value will only be saved to non-volatile memory if the menu is later exited by option **S**.

M: Change MAC number:

This number determines the MAC address for this particular card. It is set at the factory and should not be changed. It is worth making a note of this number so that it can be restored if it does get corrupted. If it gets corrupted and you don't know its value, you will have to email support@bluebell.tv with the card's actual serial number (from a printed label on the card) and they should be able to tell you the MAC serial number to be entered.

To change the value, type **M** which will give the response:

New Setting:

Enter the new decimal MAC serial number and press **Return**. The card will refresh the menu showing the new value. Note that any new value will only be saved to non-volatile memory if the menu is later exited by option **S**.

The "MAC number" is the decimal equivalent of the last two bytes of the MAC address, with the first four bytes being 00.50.C2.7C. For the example screen given above, the decimal number 37133 when converted to hexadecimal is 910D. So, the MAC address for this card would be 00.50.C2.7C.91.0D.

S: Save & Quit.

This option, **S**, will save the settings currently displayed on the menu to non-volatile memory so that these settings will be restored every time the card is powered up or reset. The card then starts normal operation, as though the card had powered with the hex switch at 0. It is probably best to return the hex switch to 0 to avoid invoking this menu (and suspending normal operation) after the next power cycle or reset.

Q: Quit without saving.

This option, or the **Esc** key (not shown on the menu), will quit the configuration menu and start normal card operation without saving any changes to non-volatile memory. If any settings were changed, the new values will remain active until the next power-down or reset, after which the old values will be restored. This allows any new values to be tested before committing them to non-volatile memory. Please note that this does not apply to Image files (web pages) uploaded via menu option **I**, as these are saved directly to non-volatile memory.

Other keys

If any key other than those listed above is pressed then the menu will simply refresh with the current values, giving another chance to select one of the listed options.

Normal operation

Please note, that if options **S**, **Q**, or **Esc** are selected, the card will start normal operation, with the status LED flashing. However, if the OPTIONS switch on the front panel is left on "F", at the next power up or reset, the card will re-enter the configuration menu and wait for an option to be selected. To return to normal operation fully, ensure the OPTIONS switch is set back to "0".

Also note that when options **S**, **Q**, or **Esc** are used to exit the menu, the card will show the current IP address. It will also show the IP address whenever it is changed, by a DHCP server, for example. Thus, it may be useful to leave the Terminal emulator program running to monitor any IP address changes if you are having any network problems.

In normal operation, you can type **S** in the terminal emulator at any time to show some status information on the card, including the current IP address. This is part of an engineering debug facility that is beyond the scope of this manual, so you are advised not to type anything other than **S** as the results will be unpredictable.

Operations

Once configured, a card's operation can be checked via its Ethernet port. The card's STATUS LED should be flashing once per second to indicate normal operation. If it isn't, ensure that the OPTIONS switch is set to '0' and press the RESET switch.

Network Port

This RJ45 connector on the front panel is for an Ethernet cable. This would normally be a straight (non-crossover) cable connecting to an Ethernet hub, switch, or router. Please note that if connecting the BM102i directly to a PC's Ethernet port, a crossover type cable may be required.

Each card should have a unique MAC address that is set at the factory, and should not be changed. For more information on MAC address, look under the **Network Configuration page**.

The card's Host name and IP address should have been determined by the configuration process above and one of these needs to be known to access the card as described in this section.

'Pinging' the Card

If the IP address is known, a quick check of Ethernet connectivity between the card and a PC on the same network can be achieved by opening up a Command Prompt window on the PC and typing, for example (using default IP address):

```
C:\>ping 192.168.16.200
```

This utility sends 4 packets to the given address and checks for a response from each one. The key part of a successful response to look out for would be something like:-

```
Packets: Sent = 4, Received = 4, Lost = 0 (0% loss)
```

If a failure is indicated, you may need to check with the local Network administrator or IT specialist to ensure that the card, router, and PC all have compatible network settings.

Internal Web Pages

Each BM102i has a built-in web server. Simply start up an internet browser on a PC and type the card's Host Name or its IP address as a web address, so for example, a card with default settings would be addressed as:

Or: <http://bm102i/>
<http://192.168.16.200/>

This should produce the card's home page, labelled "Overview".

The "Overview" page shows the status of each of two channels (A and B) on up to 15 cards, plus the status of the two power supplies and the fans. It also shows the temperature sensed on the frame. All these values are updated at regular intervals for a dynamic display of the card's status. If a card is added/removed in a slot, the reported card slot will automatically update with the parameters of the new card, as well as the changeable parameters listed above.

For any cards in the frame, the channel status values are shown as a green LED for good (signal present) and a red LED for a fault (e.g. signal missing). Any 'old' cards will ONLY show a red LED for a fault (e.g. signal missing). However, the BM102i cannot detect the presence of an 'old' card, and so an off LED (grey) can mean either no card in the slot, or an 'old' card with signals present.

In many cases, this good/fault status is the same as that reported by an LED on the panel of the card in the relevant slot. See the manuals for the individual cards for more information on this status.

The power supplies will show as green LEDs for good supply or a red LED for a faulty or absent supply. The Fan status LED will likewise show as either red or green.

Fans are standard on the BC160i-1RU frames but optional on the BC100i-3RU frames. Frames without fans will still show red for fans as it which may still indicate a fault. The fans each have a detector chip that latches a fault condition to ensure that an intermittent fault is not missed. The latched fault condition can only be cleared by a power down, which would be required to investigate the fault. The fans are not hot-swappable on either frame size.

All the web pages have tabs in a line just below the logo and title bar, to select the other internal web pages.

The 'Frame Information' page provides access to further information for each card additional to the basic signal information on the Overview page. It shows all the information for one 'slot' at a time. Please refer to **Frame Information Page** for further details. If a card is added/removed in a slot, the 'Refresh page' option on the browser should be selected to update the static parameters of the new card.

The **Network Configuration** and **SNMP Configuration** pages are password protected. They are described in the **Configuration via Ethernet** section above.

SNMP

In SNMP terminology, the BM102i acts as an Agent, to be monitored by a Network Management System (NMS). The NMS is likely to be a PC running an SNMP browser or other SNMP control system, connected by a network to the ethernet port of one or more BM102i cards. The BM102i uses SNMP version v2c and will accept either v1 or v2c commands. It is also capable of issuing v1 or v2 traps.

The NMS needs to know what values it can read from and write to the card, and this information is provided in a "Management Information Base" or MIB file. Such a file might have a filename like: -

Bluebell-BM102i-02.mib

Where the '02' is the revision of the MIB file.

For the appropriate mib file for your card, please email: support@bluebell.tv quoting the serial number of your card, and the Firmware and Image Dates shown at the bottom of the **Overview Page**.

The NMS can issue 'Get', 'GetNext', and 'Set' commands to access the parameters of the card. The various parameters that the BM102i can deal with are each assigned an Object Identifier number (OID) and these are listed in the tables below. In these tables, 'E' represents the 'enterprise' OID: 1.3.6.1.4.1.29054

The parameters can be divided into 2 groups.

Group 1 - 'Basic' parameters

The first group are the 'basic' parameters. They are listed in the first table below.

The read-write values in the table are non-volatile and will survive card power-downs.

NAME	OID	ACCESS	DESCRIPTION / TYPICAL VALUE
sysDescr	1.3.6.1.2.1.1.1	read-only	BM102i
sysObjectID	1.3.6.1.2.1.1.2	read-only	E.1.1.3
sysUpTime	1.3.6.1.2.1.1.3	read-only	Time since reset (units = 10ms)
sysContact	1.3.6.1.2.1.1.4	read-write	support@company.com
sysName	1.3.6.1.2.1.1.5	read-write	BC-Series Frame
sysLocation	1.3.6.1.2.1.1.6	read-write	Frame number
sysServices	1.3.6.1.2.1.1.7	read-only	7
name	E.1.1.3.1.1	read-only	Bluebell BM102i
version	E.1.1.3.1.2	read-only	V1.0
date	E.1.1.3.1.3	read-only	Jun 19 2019 16:50:00
trapReceiverNumber	E.1.1.3.2.1.1.1	N/A	Index of trap receiver
trapEnabled	E.1.1.3.2.1.1.2	read-write	Is this trap entry enabled or not.
trapReceiverIPAddress	E.1.1.3.2.1.1.3	read-write	Trap receiver IP address
trapCommunity	E.1.1.3.2.1.1.4	read-write	Community name for trap messages
sig1A	E.1.1.3.3.1.1	read-only	good (0) / fail (1)
sig1B	E.1.1.3.3.1.2	read-only	good (0) / fail (1)
sig2A	E.1.1.3.3.1.3	read-only	good (0) / fail (1)
sig2B	E.1.1.3.3.1.4	read-only	good (0) / fail (1)
sig3A	E.1.1.3.3.1.5	read-only	good (0) / fail (1)
sig3B	E.1.1.3.3.1.6	read-only	good (0) / fail (1)
sig4A	E.1.1.3.3.1.7	read-only	good (0) / fail (1)
sig4B	E.1.1.3.3.1.8	read-only	good (0) / fail (1)
sig5A	E.1.1.3.3.1.9	read-only	good (0) / fail (1)
sig5B	E.1.1.3.3.1.10	read-only	good (0) / fail (1)
sig6A	E.1.1.3.3.1.11	read-only	good (0) / fail (1)
sig6B	E.1.1.3.3.1.12	read-only	good (0) / fail (1)
sig7A	E.1.1.3.3.1.13	read-only	good (0) / fail (1)
sig7B	E.1.1.3.3.1.14	read-only	good (0) / fail (1)
sig8A	E.1.1.3.3.1.15	read-only	good (0) / fail (1)
sig8B	E.1.1.3.3.1.16	read-only	good (0) / fail (1)
sig9A	E.1.1.3.3.1.17	read-only	good (0) / fail (1)
sig9B	E.1.1.3.3.1.18	read-only	good (0) / fail (1)
sig10A	E.1.1.3.3.1.19	read-only	good (0) / fail (1)
sig10B	E.1.1.3.3.1.20	read-only	good (0) / fail (1)
sig11A	E.1.1.3.3.1.21	read-only	good (0) / fail (1)
sig11B	E.1.1.3.3.1.22	read-only	good (0) / fail (1)
sig12A	E.1.1.3.3.1.23	read-only	good (0) / fail (1)
sig12B	E.1.1.3.3.1.24	read-only	good (0) / fail (1)
sig13A	E.1.1.3.3.1.25	read-only	good (0) / fail (1)
sig13B	E.1.1.3.3.1.26	read-only	good (0) / fail (1)
sig14A	E.1.1.3.3.1.27	read-only	good (0) / fail (1)
sig14B	E.1.1.3.3.1.28	read-only	good (0) / fail (1)
sig15A	E.1.1.3.3.1.29	read-only	good (0) / fail (1)
sig15B	E.1.1.3.3.1.30	read-only	good (0) / fail (1)
psu1	E.1.1.3.3.1.31	read-only	good (0) / fail (1)
psu2	E.1.1.3.3.1.32	read-only	good (0) / fail (1)
fanStatus	E.1.1.3.3.1.33	read-only	good (0) / fail (1)

In the table above "version" refers to the internal structure of the mib parameters, and "date" refers to the revision of the Image file installed (web pages and mib structure). (For the firmware version, see the group 2 parameter cardFwRev for the BM102i slot 16.)

The "trap..." parameters are part of a table with two entries, so each parameter can have two values.

The signal name "sig5B", for example, means channel B of the card in slot 5 (either 15-slot BC100i or 6-slot BC160i frame). In many cases, this status is the same as that reported by an LED on the front panel of the card in the relevant slot. The channel status values are reported as "0" or "good" for signal present and "1" or "fail" for a fault (e.g. signal missing). See the manuals for the individual cards for more information on this status. The power supplies and fans also report as "0" for good and "1" for a fault.

If a slot in the frame has no card fitted, its channels will be reported as "0", and so a missing card cannot be distinguished from a good card with signals present. If a power supply is missing, however, it will report as "1" or "fail".

Group 2 - 'CardTable' parameters

The second group consists largely of fixed information from each card, such as its part number and serial number, etc. Also, from any SFP module fitted to the card it provides both fixed information such as its manufacturer and part number and variable information such as its temperature, signal power etc.

Because of the large number of parameters, they are presented as an SNMP table, with the slot number as the index to the table, so that slot numbers 1 through 15 correspond to the 15 cards in a BC100i frame. A BC160i frame has only slots 1 through 6 and so slots 7 through 15 should be ignored.

For completeness the 'basic' statuses of channel A and B signal loss are also duplicated in the table. Since the table is only applicable to 'new' cards, whose presence can be detected, the basic statuses here have 3 states: good, bad, or unknown, where 'unknown' means either no card present, or an 'old' card with a good signal. A user thus has the choice of accessing these basic statuses from the new table, or individually in the basic form above.

The frame itself can provide the same fixed information as the cards, such as its part number and serial number, etc. and so this has been included in the table as slot 0. In this case, the signal loss parameters of channel A and B are used to provide the PSU1 and PSU2 fault signals respectively.

Similarly, the BM102i card itself will report its fixed information (serial number etc.) as slot 16 in either a 15-slot BC100i or a 6-slot BC160i. In this case, the card's signal loss parameter for channel A is used to report the fan status for the frame.

NAME	OID	ACCESS	DESCRIPTION / TYPICAL VALUE	Notes
cardSlot	E.1.1.3.3.2.1.1	N/A	Index of card table	
cardPresent	E.1.1.3.3.2.1.2	read-only	notPresent (0) / present (1)	
cardType	E.1.1.3.3.2.1.3	read-only	Card Model e.g. "BC390R"	
cardSerNo	E.1.1.3.3.2.1.4	read-only	Serial number, from bottom line of card label	
cardHwRev	E.1.1.3.3.2.1.5	read-only	Normally PCB issue number	
cardFwRev	E.1.1.3.3.2.1.6	read-only	Revision of any firmware on card	
cardFunc	E.1.1.3.3.2.1.7	read-only	Brief description of card function	
cardSigChA	E.1.1.3.3.2.1.8	read-only	unknown (0) / fail (1) / good (2)	1, 2, 3
cardSigChB	E.1.1.3.3.2.1.9	read-only	unknown (0) / fail (1) / good (2)	1, 2
sfpMfr	E.1.1.3.3.2.1.10	read-only	Name of manufacturer of SFP fitted	
sfpType	E.1.1.3.3.2.1.11	read-only	SFP model name	
sfpTemp	E.1.1.3.3.2.1.12	read-only	temperature read from SFP in degrees C.	
sfpTempStat	E.1.1.3.3.2.1.13	read-only	0-5 = n/a, too low, low, ok, high, too high	5
sfpVolt	E.1.1.3.3.2.1.14	read-only	SFP supply voltage in mV, typically 3300	4
sfpVoltStat	E.1.1.3.3.2.1.15	read-only	0-5 = n/a, too low, low, ok, high, too high	5
sfpDirCh1	E.1.1.3.3.2.1.16	read-only	Ch1 sig direction: unknown (0), Tx (1), Rx (2)	
sfpDirCh2	E.1.1.3.3.2.1.17	read-only	Ch2 sig direction: unknown (0), Tx (1), Rx (2)	
sfpWlCh1	E.1.1.3.3.2.1.18	read-only	Ch1 wavelength (if transmitter) in nm	
sfpWlCh2	E.1.1.3.3.2.1.19	read-only	Ch2 wavelength (if transmitter) in nm	
sfpBiasCh1	E.1.1.3.3.2.1.20	read-only	Ch1 bias current (if transmitter) in mA	
sfpBiasCh2	E.1.1.3.3.2.1.21	read-only	Ch2 bias current (if transmitter) in mA	
sfpBiasStatCh1	E.1.1.3.3.2.1.22	read-only	Ch1: 0-5 = n/a, too low, low, ok, high, too high	5
sfpBiasStatCh2	E.1.1.3.3.2.1.23	read-only	Ch2: 0-5 = n/a, too low, low, ok, high, too high	5
sfpPowerCh1	E.1.1.3.3.2.1.24	read-only	Ch1 optical power in μ W	
sfpPowerCh2	E.1.1.3.3.2.1.25	read-only	Ch2 optical power in μ W	
sfpPowerStatCh1	E.1.1.3.3.2.1.26	read-only	Ch1: 0-5 = n/a, too low, low, ok, high, too high	5
sfpPowerStatCh2	E.1.1.3.3.2.1.27	read-only	Ch2: 0-5 = n/a, too low, low, ok, high, too high	5
sfp2Mfr	E.1.1.3.3.2.1.28	read-only	Name of manufacturer of SFP fitted	
sfp2Type	E.1.1.3.3.2.1.29	read-only	SFP model name	
sfp2Temp	E.1.1.3.3.2.1.30	read-only	temperature read from SFP in degrees C.	
sfp2TempStat	E.1.1.3.3.2.1.31	read-only	0-5 = n/a, too low, low, ok, high, too high	5
sfp2Volt	E.1.1.3.3.2.1.32	read-only	SFP supply voltage in mV, typically 3300	4
sfp2VoltStat	E.1.1.3.3.2.1.32	read-only	0-5 = n/a, too low, low, ok, high, too high	5
sfp2DirCh1	E.1.1.3.3.2.1.34	read-only	Ch1 sig direction: unknown (0), Tx (1), Rx (2)	
sfp2DirCh2	E.1.1.3.3.2.1.35	read-only	Ch2 sig direction: unknown (0), Tx (1), Rx (2)	
sfp2WlCh1	E.1.1.3.3.2.1.36	read-only	Ch1 wavelength (if transmitter) in nm	
sfp2WlCh2	E.1.1.3.3.2.1.37	read-only	Ch2 wavelength (if transmitter) in nm	
sfp2BiasCh1	E.1.1.3.3.2.1.38	read-only	Ch1 bias current (if transmitter) in mA	
sfp2BiasCh2	E.1.1.3.3.2.1.39	read-only	Ch2 bias current (if transmitter) in mA	
sfp2BiasStatCh1	E.1.1.3.3.2.1.40	read-only	Ch1: 0-5 = n/a, too low, low, ok, high, too high	5
sfp2BiasStatCh2	E.1.1.3.3.2.1.41	read-only	Ch2: 0-5 = n/a, too low, low, ok, high, too high	5
sfp2PowerCh1	E.1.1.3.3.2.1.42	read-only	Ch1 optical power in μ W	
sfp2PowerCh2	E.1.1.3.3.2.1.43	read-only	Ch2 optical power in μ W	
sfp2PowerStatCh1	E.1.1.3.3.2.1.44	read-only	Ch1: 0-5 = n/a, too low, low, ok, high, too high	5
sfp2PowerStatCh2	E.1.1.3.3.2.1.45	read-only	Ch2: 0-5 = n/a, too low, low, ok, high, too high	5
sfp3Mfr	E.1.1.3.3.2.1.46	read-only	Name of manufacturer of SFP fitted	
sfp3Type	E.1.1.3.3.2.1.47	read-only	SFP model name	

sfp3Temp	E.1.1.3.3.2.1.48	read-only	temperature read from SFP in degrees C.	
sfp3TempStat	E.1.1.3.3.2.1.49	read-only	0-5 = n/a, too low, low, ok, high, too high	5
sfp3Volt	E.1.1.3.3.2.1.50	read-only	SFP supply voltage in mV, typically 3300	4
sfp3VoltStat	E.1.1.3.3.2.1.51	read-only	0-5 = n/a, too low, low, ok, high, too high	5
sfp3DirCh1	E.1.1.3.3.2.1.52	read-only	Ch1 sig direction: unknown (0), Tx (1), Rx (2)	
sfp3DirCh2	E.1.1.3.3.2.1.53	read-only	Ch2 sig direction: unknown (0), Tx (1), Rx (2)	
sfp3WlCh1	E.1.1.3.3.2.1.54	read-only	Ch1 wavelength (if transmitter) in nm	
sfp3WlCh2	E.1.1.3.3.2.1.55	read-only	Ch2 wavelength (if transmitter) in nm	
sfp3BiasCh1	E.1.1.3.3.2.1.56	read-only	Ch1 bias current (if transmitter) in mA	
sfp3BiasCh2	E.1.1.3.3.2.1.57	read-only	Ch2 bias current (if transmitter) in mA	
sfp3BiasStatCh1	E.1.1.3.3.2.1.58	read-only	Ch1: 0-5 = n/a, too low, low, ok, high, too high	5
sfp3BiasStatCh2	E.1.1.3.3.2.1.59	read-only	Ch2: 0-5 = n/a, too low, low, ok, high, too high	5
sfp3PowerCh1	E.1.1.3.3.2.1.60	read-only	Ch1 optical power in μ W	
sfp3PowerCh2	E.1.1.3.3.2.1.61	read-only	Ch2 optical power in μ W	
sfp3PowerStatCh1	E.1.1.3.3.2.1.62	read-only	Ch1: 0-5 = n/a, too low, low, ok, high, too high	5
sfp3PowerStatCh2	E.1.1.3.3.2.1.63	read-only	Ch2: 0-5 = n/a, too low, low, ok, high, too high	5
sfp4Mfr	E.1.1.3.3.2.1.64	read-only	Name of manufacturer of SFP fitted	
sfp4Type	E.1.1.3.3.2.1.65	read-only	SFP model name	
sfp4Temp	E.1.1.3.3.2.1.66	read-only	temperature read from SFP in degrees C.	
sfp4TempStat	E.1.1.3.3.2.1.67	read-only	0-5 = n/a, too low, low, ok, high, too high	5
sfp4Volt	E.1.1.3.3.2.1.68	read-only	SFP supply voltage in mV, typically 3300	4
sfp4VoltStat	E.1.1.3.3.2.1.69	read-only	0-5 = n/a, too low, low, ok, high, too high	5
sfp4DirCh1	E.1.1.3.3.2.1.70	read-only	Ch1 sig direction: unknown (0), Tx (1), Rx (2)	
sfp4DirCh2	E.1.1.3.3.2.1.71	read-only	Ch2 sig direction: unknown (0), Tx (1), Rx (2)	
sfp4WlCh1	E.1.1.3.3.2.1.72	read-only	Ch1 wavelength (if transmitter) in nm	
sfp4WlCh2	E.1.1.3.3.2.1.73	read-only	Ch2 wavelength (if transmitter) in nm	
sfp4BiasCh1	E.1.1.3.3.2.1.74	read-only	Ch1 bias current (if transmitter) in mA	
sfp4BiasCh2	E.1.1.3.3.2.1.75	read-only	Ch2 bias current (if transmitter) in mA	
sfp4BiasStatCh1	E.1.1.3.3.2.1.76	read-only	Ch1: 0-5 = n/a, too low, low, ok, high, too high	5
sfp4BiasStatCh2	E.1.1.3.3.2.1.77	read-only	Ch2: 0-5 = n/a, too low, low, ok, high, too high	5
sfp4PowerCh1	E.1.1.3.3.2.1.78	read-only	Ch1 optical power in μ W	
sfp4PowerCh2	E.1.1.3.3.2.1.79	read-only	Ch2 optical power in μ W	
sfp4PowerStatCh1	E.1.1.3.3.2.1.80	read-only	Ch1: 0-5 = n/a, too low, low, ok, high, too high	5
sfp4PowerStatCh2	E.1.1.3.3.2.1.81	read-only	Ch2: 0-5 = n/a, too low, low, ok, high, too high	5
cspCount	E.1.1.3.3.2.1.82	read-only	Number of CSPs the card can display	
cspDesc1	E.1.1.3.3.2.1.83	read-only	Card Specific Parameter Description 1	
cspDesc2	E.1.1.3.3.2.1.84	read-only	Card Specific Parameter Description 2	
cspDesc3	E.1.1.3.3.2.1.85	read-only	Card Specific Parameter Description 3	
cspDesc4	E.1.1.3.3.2.1.86	read-only	Card Specific Parameter Description 4	
cspDesc5	E.1.1.3.3.2.1.87	read-only	Card Specific Parameter Description 5	
cspDesc6	E.1.1.3.3.2.1.88	read-only	Card Specific Parameter Description 6	
cspDesc7	E.1.1.3.3.2.1.89	read-only	Card Specific Parameter Description 7	
cspDesc8	E.1.1.3.3.2.1.90	read-only	Card Specific Parameter Description 8	
cspDesc9	E.1.1.3.3.2.1.91	read-only	Card Specific Parameter Description 9	
cspDesc10	E.1.1.3.3.2.1.92	read-only	Card Specific Parameter Description 10	
cspDesc11	E.1.1.3.3.2.1.93	read-only	Card Specific Parameter Description 11	
cspDesc12	E.1.1.3.3.2.1.94	read-only	Card Specific Parameter Description 12	
cspDesc13	E.1.1.3.3.2.1.95	read-only	Card Specific Parameter Description 13	
cspDesc14	E.1.1.3.3.2.1.96	read-only	Card Specific Parameter Description 14	

cspDesc15	E.1.1.3.3.2.1.97	read-only	Card Specific Parameter Description 15	
cspDesc16	E.1.1.3.3.2.1.98	read-only	Card Specific Parameter Description 16	
cspValue1	E.1.1.3.3.2.1.99	read-only	Card Specific Parameter Value 1	
cspValue2	E.1.1.3.3.2.1.100	read-only	Card Specific Parameter Value 2	
cspValue3	E.1.1.3.3.2.1.101	read-only	Card Specific Parameter Value 3	
cspValue4	E.1.1.3.3.2.1.102	read-only	Card Specific Parameter Value 4	
cspValue5	E.1.1.3.3.2.1.103	read-only	Card Specific Parameter Value 5	
cspValue6	E.1.1.3.3.2.1.104	read-only	Card Specific Parameter Value 6	
cspValue7	E.1.1.3.3.2.1.105	read-only	Card Specific Parameter Value 7	
cspValue8	E.1.1.3.3.2.1.106	read-only	Card Specific Parameter Value 8	
cspValue9	E.1.1.3.3.2.1.107	read-only	Card Specific Parameter Value 9	
cspValue10	E.1.1.3.3.2.1.108	read-only	Card Specific Parameter Value 10	
cspValue11	E.1.1.3.3.2.1.109	read-only	Card Specific Parameter Value 11	
cspValue12	E.1.1.3.3.2.1.110	read-only	Card Specific Parameter Value 12	
cspValue13	E.1.1.3.3.2.1.111	read-only	Card Specific Parameter Value 13	
cspValue14	E.1.1.3.3.2.1.112	read-only	Card Specific Parameter Value 14	
cspValue15	E.1.1.3.3.2.1.113	read-only	Card Specific Parameter Value 15	
cspValue16	E.1.1.3.3.2.1.114	read-only	Card Specific Parameter Value 16	

NOTE:

1. These statuses are the same as that in the 'basic' table above, except they are qualified by cardPresent (i.e. 'new' card detected) 'unknown' means no 'new' card detected: could be 'old' card with good signal. 'fail' means card reporting signal loss ('old' or 'new' card) 'good' means 'new' card detected, with good signal
2. For slot 0 (the frame itself), cardSigChA reports the status of PSU 1.
For slot 0 (the frame itself), cardSigChB reports the status of PSU 2.
3. For slot 16 (the BM102i card), cardSigChA reports the status of the frame fans.
4. For slot 0 (frame) or 16 (BM102i), sfpVolt, sfp2Volt, sfpVoltStat, and sfp2VoltStat are derived from the motherboard supply voltage, sensed on the BM102i, typically 6000mV.
5. "n/a" means not applicable (for all the ...Stat.. parameters)

SNMP Traps

Normally, the Network Management System (NMS) issues requests for information and the BM102i provides the appropriate responses. However, to get quicker notification of a fault condition, the BM102i can be set up to initiate a message, called a Trap, to one or two NMS computers.

When traps are enabled, they are generated for a change of state (on or off) for any of the 33 'basic' frame signals: 2 channels on each 15 cards, 2 power supplies and fan status.

Configuring Traps

The settings for configuring traps are controlled via SNMP, and they are non-volatile. Traps are set up by issuing SNMP 'Set' commands to the relevant 'trap...' parameters in the 'Basic' table above. The two trap generators can be individually enabled or disabled, and for each trap generator, a destination IP address and an SNMP 'community' name can be specified. The parameters are listed here:

trapReceiverNumber (1.3.6.1.4.1.29054.1.1.3.2.1.1.1)

This parameter is not accessed directly but is the index (0 or 1) to select the required trap generator when accessing the remaining 3 parameters.

For example, for the next parameter, trapEnabled,

1.3.6.1.4.1.29054.1.1.3.2.1.1.2.0 controls trap generator 0, and

1.3.6.1.4.1.29054.1.1.3.2.1.1.2.1 controls trap generator 1.

trapEnabled (1.3.6.1.4.1.29054.1.1.3.2.1.1.2)

This parameter can be set to '0' to disable that trap generator or '1' to enable it. The other parameters are still remembered when the generator is disabled.

trapReceiverIPAddress (1.3.6.1.4.1.29054.1.1.3.2.1.1.3)

This parameter is the destination address for the trap and should be set to the IP address of the computer running the Network Management System that will display and log the traps.

trapCommunity (1.3.6.1.4.1.29054.1.1.3.2.1.1.4)

This parameter should be set with a text string that will be used as the community name in any traps that are sent. The text can be no more than 31 characters.

Generating Traps

When traps are enabled, they are generated by a change of state (on or off) for any of the 33 'basic' frame signals, that is:

sig1A, sig1B, sig2A, sig2B

etc. up to...

sig15A, sig15B, psu1, psu2, fans